

# Excellence in Physics

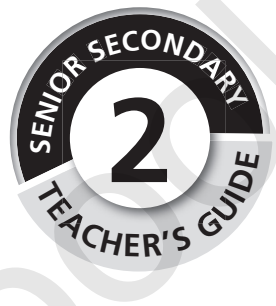

For Ebooks uses

*Published by Cambridge University Press*  
Shaftesbury Road, Cambridge CB2 8EA, United Kingdom

*Distributed in Nigeria by Cambridge University Press Nigeria Ltd*  
252E Muri Okunola Street, Victoria Island, Lagos State, Nigeria

Cambridge University Press & Assessment is part of the University of Cambridge.

It furthers the University's mission by disseminating knowledge in the pursuit of education, learning and research at the highest international levels of excellence.

First published 2016

Printed in India by Multivista Global Pvt Ltd.

ISBN 978-1-316-50493-2 Paperback

Authors: Jagathesan Govender and Sirion Robertson

Designer: Mellany Fick

Editor: Louis Botes

Illustrator: Beverley Victor

Typesetter: Orchard Publishing

Cover image: Bigstock, © 1971yes

---

Every effort has been made to trace copyright holders. Should any infringements have occurred, please inform the publishers who will correct these in the event of a reprint.

For Ebook Uses

# Contents

Introduction .....	iv
Scheme of work .....	vii
<b>Theme 1 Interaction of matter, space and time .....</b>	<b>1</b>
Topic 1 Position, distance and displacement .....	1
Topic 2 Vectors .....	3
Topic 3 Speed, velocity and acceleration .....	4
Topic 4 Equations of uniformly accelerated motion .....	8
Topic 5 Equilibrium of forces .....	10
Topic 6 Projectiles .....	13
Topic 7 Simple harmonic motion .....	15
<b>Theme 2 Conservation principles .....</b>	<b>17</b>
Topic 1 Linear momentum .....	17
Topic 2 Mechanical energy .....	20
Topic 3 (A) Heat energy: Temperature and its measurement .....	22
Topic 3 (B) Heat energy: Heat energy measurements .....	26
Topic 4 Gas laws .....	32
<b>Theme 3 Waves – motion without material transfer .....</b>	<b>36</b>
Topic 1 Production and propagation of waves .....	36
Topic 2 Types of waves .....	39
Topic 3 Properties of waves .....	41
Topic 4 Light waves .....	44
Topic 5 Sound waves .....	47
Topic 6 The human eye .....	51
Topic 7 Application of sound waves .....	53
<b>Theme 4 is not included as per the Nigerian Educational Research and Development Council (NERDC) Curriculum.</b>	
<b>Theme 5 Energy quantization and duality of matter .....</b>	<b>56</b>
Topic 1 Molecular theory of matter .....	56
<b>Theme 6 Physics in technology .....</b>	<b>58</b>
Topic 1 Application of lenses and plane mirrors .....	58
Topic 2 Musical instruments .....	60

# Introduction

## The purpose of the curriculum

The general objectives of the curriculum are to:

- provide basic literacy in Physics for functional living in society
  - ensure that students acquire basic concepts and principles of Physics as a preparation for further studies
  - ensure that students acquire essential scientific skills and attitudes as a preparation for the technological application of Physics
  - stimulate and enhance creativity.
- select appropriate content materials
  - decide on the best methods of presentation, such as PowerPoint, workstations, videos, discussion groups, worksheets, question–answer sessions, debate or experiments
  - gather equipment and other resources required for the activities
  - keep informed about new developments and news in Physics in Nigeria and the rest of the world
  - arrange outings and guest speakers from time to time.

## The goals of the curriculum

The goals of the curriculum place emphasis on:

- student-activity
- experimentation
- questioning
- discussion
- problem solving.

## Time allocation

To cover this curriculum, the recommended weekly time allocation is two periods of 40 minutes each. Students need to do regular revision at home in order to cope with the content and new terminology.

## The role of the teacher

One of the principle duties of a Physics teacher is to prepare and present good lessons to his or her students. The teacher has to:

- be as well informed as possible on the scheme of work of the subject
- know the aims and objectives of each topic

To be effective in presentation, the teacher must make a written or typed plan for each lesson. This plan must include aims, objectives, resources, time frames, content for the lesson, activities, homework, assessment and ideas or additional worksheets to cater for students requiring extension or learning support (remedial).

Prepare each topic in advance. Many teachers go into the classroom inadequately prepared. It is your responsibility as a Physics teacher to involve your students actively in the learning process. It is a proven fact that students learn far more by *doing* than by *listening*.

You should endeavour to apply the scientific method throughout. Science involves being curious and asking questions. Wherever possible, ask questions to engage the students and to encourage independent thought processes. Start your lessons by asking the students to write down answers to (approximately five) questions related to your lesson. This will settle them into the lesson.

You can ask different types of questions in your lessons:

- **diagnostic** questions to determine prior knowledge on the topic
- questions for **consolidation** of challenging concepts during the lesson
- questions for **stimulation** of interest in the subject
- questions for **concluding** the lesson. These will assist you to find out whether students have understood the concepts or terminology in the lesson. It will also highlight any areas that they need to revise at home or for you to revisit in the next lesson.

Teachers must ensure that they do not appear to have favourites in the class, so devise a system to ensure that you ask questions fairly, but be careful not to embarrass weak students if they cannot answer questions.

## How to use the book

The purposes of this Teacher's Guide are to assist you to use the Student's Book and to assist you to be more thoroughly prepared so that your teaching will be more meaningful to your students. This book supports a hands-on approach and lays a solid foundation for SS3.

You need to be familiar with the key features of the Student's Book.

The Student's Book is divided into 22 topics. Each topic is structured in the following way:

- performance objectives required by the curriculum:
- content required by the curriculum
- activities to be completed individually, with a partner, in groups or as a class
- summary of the topic
- key words – this is essential vocabulary for the topic
- practice tests for revision of the topic.

Please note that Theme 4: Fields at rest and in motion is not covered in the SS2 curriculum and is only introduced in SS3.

## How to use the scheme of work

A scheme of work is defined as the part of the curriculum that a teacher will be required to teach in any particular subject. Its primary function is to provide an outline of the subject matter and its content, and to indicate how much work a student should cover in any particular class. A scheme of work allows teachers to clarify their thinking about a subject, and to plan and develop particular curriculum experiences that they believe may require more time and attention when preparing lessons. The criteria all teachers should bear in mind when planning a scheme of work are continuity in learning and progression of experience. You can add your own notes to the scheme of work provided on pages vii to xviii.

The scheme of work is sequential. The sequence of the scheme of work is aligned with the textbook. Do not be tempted to jump around. Rather spend time carefully planning the term to ensure that you adhere to the scheme of work.

The year is divided into three terms.

Each term is divided into 13 weeks.

There are seven topics in Term 1, nine topics in Term 2 and six topics in Term 3. The end of term allows time for revision and an examination. This time frame may vary depending on the planning of your particular school.

The right hand column gives the suggested lessons for each topic. This has been divided according to the content of the topic. These vary from two to thirteen lessons per topic.

The first lesson is usually an introduction to the topic. Make an effort to make this lesson exciting and informative. You should always explain the meaning of the topic in this lesson, for example: What is Physics? What is Matter? What is Space? What is Time? What is measurement?

The last lesson is allocated to revision. In this lesson, you can give the class a revision worksheet, a test or design a fun activity such as a game or a quiz to consolidate the topic. Students can also do their own revision by making mind maps, concept maps or other types of summaries. They can also set tests for each other.

It is important to note that these are a *suggested* number of lessons for the topic. The amount will vary according to the ability of the students in your class and their prior knowledge. Your management

of the class will have an enormous influence on your ability to adhere to the time frames. Focus on effective discipline strategies. You will have fewer discipline issues if you are punctual and well prepared, follow a plan (write this on the board at the start of the lesson), keep your word (don't make empty threats), consistently adhere to rules (especially rules related to laboratory safety) and strive to make Physics an exciting subject.

A teacher of Physics is a professional instructor who facilitates, promotes and influences students to achieve the outcomes of the scheme of work. It is the wish of the authors that the students will, at the end of each course in the series (SS1, SS2 and SS3) attain a level of proficiency in Physics that will equip them for future studies in this field.

Table 1: Physics teaching scheme of work for SS2

Term	Week	Theme	Topic	Performance objectives (Students should be able to:)	Content
1	1	Interaction of matter, space and time	1: Position, distance and displacement (SB p. 1)	1.1 Use the Cartesian system to locate the positions of objects on the x-y plane	1. Concept of position and position coordinate 2. Frames of reference
	2		2: Vectors (SB p. 4)	2.1 Explain the meaning of the 'resultant' of two or more vectors. 2.2 Resolve a vector into components 2.3 Resolve any number of vectors into two components at right angles to each other	1. Concept of vectors 2. Vector representation 3. Addition of vectors 4. Resolution of vectors
	3-4		3: Speed, velocity and acceleration (SB p. 10)	3.1 Show that speed is a scalar quantity while velocity and acceleration are vectors 3.2 Calculate resultant using simple examples of motion of bodies with one or two changes of direction 3.3 Show on a (v-t) graph the motion of a body with: <ul style="list-style-type: none"> <li>• uniform velocity</li> <li>• uniform acceleration</li> <li>• variable acceleration/instantaneous velocity</li> </ul> 3.4 Deduce the distance covered between any time intervals on the graph in (3.3) above	1. Speed as a scalar quantity 2. Velocity and acceleration as vector quantities. 3. Concept of resultant velocity using vector representation 4. v-t graphs 5. Instantaneous velocity and acceleration
	5		4: Equations of uniformly accelerated motion (SB p. 18)	4.1 Deduce the equations of motion from a v-t graph with initial velocity and constant acceleration 4.2 Explain the terms used in the equations of motion	Application and interpretation of equations of motion in simple problems

Term	Week	Theme	Topic	Performance objectives (Students should be able to:)	Content
	6–7		5: Equilibrium of forces (SB p. 24)	5.1 Distinguish between resultant and equilibrant forces 5.2 Explain the concept of equilibrium and distinguish between static and dynamic equilibrium 5.3 Explain the conditions that must be satisfied if a body is to be kept in equilibrium by the action of non-parallel forces 5.4 Explain what is meant by the moment of a force about a point 5.5 Explain what is meant by the centre of gravity of a body and identify its position for some regular uniform bodies 5.6 Name and identify three types of equilibrium with respect to the stability of an object 5.7 Explain the effect of centre of gravity on the stability of a body 5.8 Identify the forces acting on a body completely immersed in a liquid and establish the condition for the body to float on the liquid	1. Resultant and equilibrant forces 2. Parallel forces 3. Moment of force (torque) 4. Centre of gravity and equilibrium 5. Equilibrium of bodies in liquids 6. Archimedes' principle 7. Law of flotation.
	8		6: Projectiles (SB p. 34)	6.1 Identify a projectile motion 6.2 Derive the range, maximum height and time of flight of a projectile	1. Concept of a projectile 2. Simple problems involving range, height and time of flight

Term	Week	Theme	Topic	Performance objectives (Students should be able to:)	Content
	9–10		7: Simple harmonic motion (SB p. 43)	7.1 Define simple harmonic motion 7.2 Show the relationship between linear and angular speed, and linear and angular acceleration 7.3 Show the relationship between period and frequency 7.4 Calculate the energy in the system 7.5 Explain forced vibration and resonance	1. Definition of simple harmonic motion. 2. Speed and acceleration of simple harmonic motion 3. Period, frequency and amplitude of simple harmonic motion. 4. Energy of simple harmonic motion. 5. Forced vibration and resonance.
	11	Revision			
	12–13	Exams			
Term 2	1–2	Conservation principles	1: Linear momentum (SB p. 52)	1.1 State and explain in your own words the meaning of 'laws of motion' 1.2 Show graphically: <ol style="list-style-type: none"> <li>the relationship between the accelerations produced by a given set of forces acting on a single body</li> <li>the relationship between the accelerations produced by a constant force on varying masses</li> <li>know that the results from a. and b. lead to the equation <math>f = ma</math></li> </ol> 1.3 Solve simple problems based on Newton's laws of motion and the principle of momentum 1.4 State and explain the meaning of the law of conservation of linear momentum 1.5 Solve simple problems involving the conservation of linear momentum	1. Momentum and impulse. 2. Newton's Laws of motion. 3. Conservation of linear momentum. 4. Collisions. 5. Inertia, inertial mass and weight. 6. Application of Newton's laws of motion.

Term	Week	Theme	Topic	Performance objectives (Students should be able to:)	Content
				<p>1.6 Explain:</p> <ul style="list-style-type: none"> <li>• why walking is possible</li> <li>• why a gun recoils when fired</li> <li>• how a rocket is propelled</li> <li>• how a jet plane is propelled</li> </ul> <p>1.7 Explain inertial mass and the relationship between mass and weight</p> <p>1.8 Explain why the weight of a body may vary from place to place</p>	
	3-4		2: Mechanical energy (SB p. 67)	<p>2.1 Calculate the kinetic and potential energy of a body</p> <p>2.2 Verify conservation of energy principles and show that the total energy is conserved for a given set of data on the energy of a particle in a conservation field</p> <p>2.3 Define a machine and list at least five simple machines</p> <p>2.4 Define and calculate:</p> <ol style="list-style-type: none"> <li>a) force ratio</li> <li>b) velocity ratio</li> <li>c) efficiency for a simple machine, and write the mathematical relationship between a), b) and c)</li> </ol> <p>2.5 State how friction can be reduced in the moving parts of a given machine</p> <p>2.6 Perform a simple experiment using a spring balance to determine the coefficient of friction between two surfaces</p>	<ol style="list-style-type: none"> <li>1. Concept of work as a measure of energy</li> <li>2. Quantitative treatment of mechanical energy</li> <li>3. Conservation of mechanical energy</li> <li>4. Application of mechanical energy</li> <li>5. Machines:                             <ul style="list-style-type: none"> <li>• types of machine</li> <li>• force ratio (mechanical advantage)</li> <li>• velocity ratio</li> <li>• efficiency</li> </ul> </li> <li>6. Friction</li> </ol>

Term	Week	Theme	Topic	Performance objectives (Students should be able to:)	Content
	5–6		3 (A): Heat energy: Temperature and its measurement (SB p. 80)	<p>3.1 Construct a device for measuring the temperature of a body</p> <p>3.2 Use the variation of:</p> <ol style="list-style-type: none"> <li>pressure of a gas with temperature</li> <li>the expansion of a solid, liquid or gas with temperature</li> <li>electrical resistance of a material to measure the temperature of a body</li> </ol> <p>3.3 Distinguish between heat and temperature and between temperature points and temperature intervals</p> <p>3.4 Select those liquids which are suitable for use in liquid-in-glass thermometers from a given list of liquids and their properties</p> <p>3.5 State the instrument used for measuring temperature</p> <p>3.6 Explain the device for measuring the temperature of an environment</p> <p>3.7 Describe the absolute scale of temperature and explain the meaning of the absolute zero of temperature</p> <p>3.8 Convert a given temperature on the Celsius scale to a temperature on the Kelvin scale</p> <p>3.9 Describe the kinetic molecular model of temperature</p>	<ol style="list-style-type: none"> <li>Temperature and its measurements</li> <li>Thermometers <ul style="list-style-type: none"> <li>constant volume gas thermometer</li> <li>liquid-in glass thermometer</li> <li>resistance thermometer</li> <li>thermocouple</li> </ul> </li> <li>Absolute scale of temperature</li> <li>Pressure and temperature of a gas</li> <li>Pressure law</li> <li>Molecular explanation of temperature</li> </ol>

Term	Week	Theme	Topic	Performance objectives (Students should be able to:)	Content
			3 (B) Heat energy: Heat energy measurements (SB p. 199)	<p>3.1 Explain the relationship between the heat supplied to a substance, and</p> <ol style="list-style-type: none"> <li>its temperature change at a constant mass</li> <li>its mass at a constant temperature change</li> </ol> <p>3.2 Explain the terms specific heat capacity and thermal capacity</p> <p>3.3 Explain why there is an unequal rise in temperature for different substances of the same mass supplied with the same quantity of heat</p> <p>3.4 Calculate unknown quantities using the relation when no change of state is involved</p> <p>3.5 Determine the melting point of a solid and boiling point of a given liquid</p> <p>3.6 List the effects impurities and pressure on the melting of a solid and boiling point of a given liquid</p> <p>3.7 Solve simple problems involving latent heat</p> <p>3.8 Distinguish between evaporation and boiling and explain sublimation</p> <p>3.9 Explain the working experiences of such common devices as:</p> <ul style="list-style-type: none"> <li>refrigerator</li> <li>air conditioner</li> <li>pressure cooker</li> </ul> <p>3.10 Explain the effects of humidity on personal comfort</p>	<ol style="list-style-type: none"> <li>Specific heat <ul style="list-style-type: none"> <li>concept of specific heat capacity</li> <li>its measurements</li> <li>its significance</li> </ul> </li> <li>Latent heat <ul style="list-style-type: none"> <li>concept of latent heat</li> <li>measurements of specific latent heat of fusion and vaporisation</li> <li>effect of pressure and impurities on melting and boiling points</li> </ul> </li> <li>Some applications of latent heat</li> <li>Evaporation, boiling and sublimation</li> <li>Relative humidity and dew point</li> </ol>

Term	Week	Theme	Topic	Performance objectives (Students should be able to:)	Content
	7		4: Gas laws (SB p. 125)	<p>4.1 Identify and use instruments for measuring pressure</p> <p>4.2 Explain, using the ideas of the kinetic theory of gases,</p> <ul style="list-style-type: none"> <li>the variation of pressure with volume of a gas when the temperature is kept constant (Boyle's law)</li> <li>the variation of volume with temperature of a gas when the pressure is kept constant (Charles' law)</li> </ul> <p>4.3 Deduce the general gas law from a given mass of gas which obeys Charles' law</p> <p>4.4 Solve simple problems involving the gas laws</p>	<ol style="list-style-type: none"> <li>Measurement of gas pressure</li> <li>Barometers in practical use</li> <li>Boyle's law and its application</li> <li>Charles' law and its application</li> <li>General gas law</li> </ol>
	8	Waves – motion without material transfer	1: Production and propagation of waves (SB p. 141)	<ol style="list-style-type: none"> <li>1.1 Generate mechanical waves</li> <li>1.2 State the important characteristics of waves</li> <li>1.3 Produce circular and plane waves using a ripple tank.</li> <li>1.4 Generate and demonstrate longitudinal and transverse waves using suitable materials</li> <li>1.5 Identify the crest, trough, amplitude, wavelength and points in phase on a given sine wave form</li> <li>1.6 Derive and use the relationship between wave velocity, frequency and wavelength.</li> <li>1.7 Identify light as electromagnetic waves</li> </ol>	<ol style="list-style-type: none"> <li>Production of mechanical waves</li> <li>Pulsating system <ul style="list-style-type: none"> <li>energy transmitted with definite speed</li> <li>frequency and wavelength</li> </ul> </li> <li>Wave form – description and graphical representation</li> <li>Mathematical relationships among <math>f</math>, <math>\lambda</math>, <math>T</math> and <math>v</math></li> <li>Sound and light as wave phenomena</li> </ol>

Term	Week	Theme	Topic	Performance objectives (Students should be able to:)	Content
			2: Types of waves (SB p. 151)	<p>2.1 Classify waves into longitudinal and transverse waves by using</p> <ul style="list-style-type: none"> <li>• mode of vibration</li> <li>• direction of propagation</li> </ul> <p>2.2 Write down and explain the terms in the wave equation</p>	<ol style="list-style-type: none"> <li>1. Longitudinal waves</li> <li>2. Transverse waves</li> <li>3. The wave equation)</li> </ol>
	9		3: Properties of waves (SB p. 157)	<p>3.1 Produce plane and circular waves using a ripple tank</p> <p>3.2 Demonstrate the reflection of sound</p> <p>3.3 Demonstrate stationary waves</p> <p>3.4 Demonstrate the reflection of heat radiation</p> <p>3.5 Demonstrate the refraction of water waves and sound</p>	<ol style="list-style-type: none"> <li>1. Reflection of waves</li> <li>2. Laws of reflection of waves</li> <li>3. Superposition of waves <ul style="list-style-type: none"> <li>• two waves in the same direction (progressive wave)</li> <li>• two waves in opposite direction (standing or stationary waves)</li> </ul> </li> <li>4. Refraction of waves laws of refraction</li> </ol>
	10		4: Light waves (SB p. 167)	<p>4.1 List some light sources you come across in everyday life</p> <p>4.2 Determine the angle of reflection for a given angle of incidence</p> <p>4.3 Draw ray diagrams to show the formation of images by plane and curved mirrors</p> <p>4.4 Explain some practical applications of plane and curved mirrors</p> <p>4.5 Explain how the direction of light changes as it travels from one medium into another</p> <p>4.6 Measure angles of incidence and refraction and hence deduce a value for the refractive index of a given material</p>	<ol style="list-style-type: none"> <li>1. Sources of light</li> <li>2. Light and matter</li> <li>3. Transmission of light</li> <li>4. Reflection of light at: <ul style="list-style-type: none"> <li>• plane mirror surfaces</li> <li>• curved mirrors</li> </ul> </li> <li>5. Formation of images by <ul style="list-style-type: none"> <li>• plane mirrors</li> <li>• curved mirrors</li> </ul> </li> <li>6. Laws of reflection</li> <li>7. Parabolic mirror as application of reflection of light on curved surfaces</li> <li>8. Refraction of light through <ul style="list-style-type: none"> <li>• rectangular glass block</li> <li>• triangular prism</li> </ul> </li> </ol>

Term	Week	Theme	Topic	Performance objectives (Students should be able to:)	Content
				4.7 Explain the meaning of critical angle and total internal reflection, stating the conditions under which they occur 4.8 Establish the relationship between critical angle and refractive index, and apply it to the solution of simple problems 4.9 Trace light rays through a triangular prism and obtain graphically the value of the angle of minimum deviation 4.10 Obtain the spectrum of white light 4.11 Describe the spectra of solar energy received by Earth 4.12 Obtain images due to light rays through converging and diverging lenses using: <ul style="list-style-type: none"> <li>• ray tracks</li> <li>• ray tracing method</li> </ul> 4.13 Use the lens formula to solve numerical problems on lenses	9. Laws of refraction 10. Critical angle and total internal reflection 11. Angle of deviation 12. Dispersion of white light 13. Refraction of light through <ul style="list-style-type: none"> <li>• converging lenses</li> <li>• diverging lenses</li> </ul>
	11	Revision			
	12–13	Exams			

Term	Week	Theme	Topic	Performance objectives (Students should be able to:)	Content
Term 3	1-2		5: Sound waves (SB p. 183)	5.1 Identify the vibrating sources when sound is produced 5.2 Distinguish between: <ul style="list-style-type: none"> <li>• noise and music</li> <li>• intensity and loudness</li> <li>• pitch and frequency applied to sound</li> </ul> 5.3 Explain forced vibration and explain how it is used to amplify a sound 5.4 Use the relationship in solving numerical problems 5.5 Explain the formation of standing waves and produce these waves in stretched strings 5.6 Use the resonance tube to determine the velocity of sound in air	1. Sources of sound 2. Transmission of sound 3. Pitch, loudness and quality 4. Noise of music 5. Forced vibration <ul style="list-style-type: none"> <li>• resonance</li> <li>• harmonies and overtones</li> </ul> 6. Speed of sound in: <ul style="list-style-type: none"> <li>• solid</li> <li>• liquid</li> <li>• air</li> </ul> 7. Velocity of sound – its measurement 8. Stationary waves
	3		6: The human eye (SB p. 201)	6.1 Explain the role played by some parts of the eye in the formation of an image on the retina 6.2 Compare and contrast the eye and the camera 6.3 State the main defects of the eye, and their causes 6.4 Identify the type of lenses for correcting the various optical defects of the eye	1. The human eye 2. Comparison of eye and camera 3. Defects of vision 4. Correction of defects

Term	Week	Theme	Topic	Performance objectives (Students should be able to:)	Content
	4		7: Application of sound waves (SB p. 209)	<p>7.1 Classify musical instruments into:</p> <ul style="list-style-type: none"> <li>• wind instruments</li> <li>• stringed instruments</li> <li>• percussion instruments</li> </ul> <p>7.2 Explain the physical principles involved in the use of wind, string and percussion instruments</p> <p>7.3 Use the reflection of sound to explain echoes</p> <p>7.4 Give an application of echoes</p> <p>7.5 Explain the functioning of hearing aids</p>	<p>1. Wind instruments:</p> <ul style="list-style-type: none"> <li>• clarinet</li> <li>• flute</li> <li>• saxophone</li> <li>• trumpet</li> </ul> <p>2. Stringed instruments:</p> <ul style="list-style-type: none"> <li>• guitar</li> <li>• sonometer</li> <li>• piano</li> </ul> <p>3. Percussion instruments:</p> <ul style="list-style-type: none"> <li>• drum</li> <li>• bell</li> <li>• talking drum</li> </ul> <p>4. Echoes and their applications</p> <p>5. Hearing aids</p>
	5	Energy quantization and duality of matter	1: Molecular theory of matter (SB p. 224)	<p>1.1 State the fundamental assumptions of the molecular theory</p> <p>1.2 Use the molecular model to explain:</p> <ul style="list-style-type: none"> <li>• pressure in a gas</li> <li>• cohesion and adhesion</li> <li>• diffusion</li> </ul>	<p>1. Fundamental assumptions of molecular theory</p> <p>2. Pressure in a gas</p> <p>3. Cohesion and adhesion</p> <p>4. Diffusion</p>
	6	Physics in technology	1: Application of lenses and plane mirrors (SB p. 232)	<p>1.1 Construct:</p> <ul style="list-style-type: none"> <li>• a periscope</li> <li>• a box camera</li> <li>• a compound microscope</li> <li>• a telescope</li> <li>• a film projector</li> </ul>	<p>1. Simple periscope</p> <p>2. Simple camera and film projector</p> <p>3. Simple and compound microscope</p> <p>4. Telescope</p>

Term	Week	Theme	Topic	Performance objectives (Students should be able to:)	Content
				1.2 Explain the optical principles involved in: <ul style="list-style-type: none"> <li>• the snapshot camera</li> <li>• the enlarging camera</li> <li>• the copying camera</li> </ul> 1.3 Set up a single-lens projector and use it to project a film strip on a screen           1.4 Explain the formation of images by the camera and the projector by tracing rays of light through them           1.5 Trace the paths of light rays through simple and compound microscopes and a telescope	
	7		2: Musical instruments (SB p. 242)	1.1 Construct various musical instruments	Local musical instruments
	8–9	All practicals			
	10	Revision			
	11–13	Examination			

## TOPIC 1: Position, distance and displacement

### Performance objectives

1.1 use the Cartesian system to locate the positions of objects on the  $x$ - $y$  plane

## Introduction

The curriculum is based on the spiral approach, and some revision is built into the syllabus. Students should already have acquired some familiarity with the ideas of position, distance and displacement, and the topic therefore starts with some revision questions.

### Activity 1.1: Position, distance and displacement

INDIVIDUAL (SB p. 1)

#### Guidelines

This is a refresher activity to see what students remember about position, distance and displacement.

#### Answers

1. Accept all well thought out answers. One good definition of 'position' is the point or area occupied by a physical object.
2. Distance is a scalar quantity that refers to how much ground an object has covered during its motion. Displacement is a vector quantity that refers to how far out of place an object is; it is the object's overall change in position.
3. The term applies to distance.

### Activity 1.2: Draw and label Cartesian axes

INDIVIDUAL (SB p. 3)

#### Guidelines

Use your discretion as to whether to issue sheets of graph paper for the students to work

on. If you do, make sure that the students realise this is no more than a convenience. They should be able to do the necessary work with ordinary paper and a ruler.

Students are asked to draw Cartesian  $x$ - $y$  axes and fill in three points, each having a set of co-ordinates. Ensure that students understand that the Cartesian co-ordinate system is in effect an ordinary two-dimensional graph, on which any point may be precisely designated as explained.

#### How are you doing?

(SB p. 3)

Take this opportunity to ask students if there is anything that they do not understand. You can check their understanding by asking them some questions about the information covered in the unit. Explain anything that students do not understand.

#### Key words

**Cartesian** – of or relating to Descartes, his mathematical methods, or his philosophy, especially with regard to its emphasis on logical analysis and its mechanistic interpretation of physical nature

**formalism** – in science, a broad term for a family of approaches to the presentation of science

**mnemonic** – a simple rule or association to help you remember something

## Practice test: Answers

1. A frame of reference is the set of points, axes or bodies we use in order to determine positions and movements. (5)
2. The  $x$ -axis is parallel to the bottom edge of the page. The  $y$ -axis is the vertical axis. (2)
3. 'Formalisms' are agreed ways of doing things. Formalisms allow for standardisation of procedures and for comparison of data and methods. (5)
4. Students should understand the formalism by which pairs of co-ordinates are plotted on a graph. The  $x$ -axis co-ordinate is always given first, so this value is the one plotted on the  $x$ -axis. If they are required to perform this simple exercise it will be immediately apparent whether or not they have grasped the idea. (4)

**Total mark: 16**

## TOPIC 2: Vectors

### Performance objectives

- 2.1 explain the meaning of the 'resultant' of two or more vectors
- 2.2 resolve a vector into components
- 2.3 resolve any number of vectors into two components at right angles to each other

## Introduction

Again the topic starts with a brief test. If any members of the class are unable to answer the revision questions, allocate a short time to revise the fundamentals of vectors. Students who fail to remember the material should be set some revision for homework. Vectors are important in later work in the course (and in mechanics generally), so take special care to see that the entire class is comfortable with the topic, and with simple vector constructions and problems, before moving on.

### Activity 1.3: Using a force board (= a 'force table') GROUPS (SB p. 7)

#### Guidelines

If your school science laboratory has force boards, demonstrate how they are used, and then allow the students to work with them in small groups. If no force boards are available, a few minutes' sketching and explaining to the class will convey the idea.

### How are you doing? (SB p. 9)

Take this opportunity to ask students if there is anything that they do not understand. You can check their understanding by asking them some questions about the information covered in the unit. Explain anything that students do not understand.

### Key words

**component vectors** – a resultant vector is made up (or is the result) of two component vectors

**equilibrium** – a state in which opposing forces or actions are balanced so that one is not stronger or greater than the other

**resolve (vectors)** – to break up a vector into components (along the  $x$ ,  $y$ , and  $z$ -axis)

## Practice test: Answers

1. The resultant of two vectors may be described as the 'combined effect' of two vectors. Students should be able to use both the described methods for constructing resultants from two vectors. (10)
2. Call for a volunteer from the class to draw these displacements on the board, and to explain the procedure. (10)
3. a) False (1)  
b) False (1)  
c) False (1)

**Total mark: 23**

## TOPIC 3: Speed, velocity and acceleration

### Performance objectives

- 3.1** show that speed is a scalar quantity, while velocity and acceleration are vectors
- 3.2** calculate resultant using simple examples of motion of bodies with one or two changes of direction
- 3.3** show on a ( $v$ - $t$ ) graph the motion of a body with:
- **uniform** velocity
  - **uniform** acceleration
  - **variable** acceleration/instantaneous velocity
- 3.4** deduce the distance covered between any time intervals on the graph in (3.3) above

## Introduction

We have always held it a privilege to teach physics to schoolchildren. If mathematics is the first language of nature, then physics is certainly nature's first additional language, and for physicists some bilinguality is essential. School-level physics makes gentle but real demands on developing intellects, and richly repays a small investment of thought with the pleasure of consciously reaching an understanding. Physics is a gymnasium for young minds, and gives older minds a pleasant way of 'keeping in shape'.

In order not to obscure these aspects and advantages of the subject, we try to steer students away from 'rote learning', and concentrate instead on assisting them to acquire a conceptual familiarity with the material. The science of mechanics, perhaps more than any other branch of physics, lends itself to the conceptual approach.

Answers to 'revision questions' at the beginning of the topic:

1. Average speed =  $\frac{\text{distance}}{\text{time}}$ .
2. Average velocity =  $\frac{\text{displacement}}{\text{time}}$ .
3. Acceleration involves a force, or 'net force' acting on the accelerating body. Also, a change in direction of motion implies an acceleration (i.e. the influence of a force).
4. Acceleration (at least linear acceleration) is expressed (as SI units) in  $\text{m/s}^2$ .
5. Acceleration due to Earth's gravity, near the Earth's surface, is given by the

(italicised) symbol  $g$ , and is equal to  $9.8 \text{ m/s}^2$ .

### Activity 1.4: Revision questions on graphs

INDIVIDUAL (SB p. 12)

#### Answers

1. The  $x$ -axis is the 'abscissa' and the  $y$ -axis is the 'ordinate'.
2. The 'independent variable' is one which you, as the experimenter, do not control. If you are 'plotting' the masses of baby mice as they grow, you are free to decide whether to weigh them every day, or every week, etc. That is the 'independent variable'. But you do not control the actual values of the masses you record. Mass, therefore, is the dependent variable. (It 'depends on' your choice of the other variable.) Conventionally, the dependent variable is plotted on the ordinate (' $y$ -axis'). The masses you record will depend on when you record the masses. Ordinarily the dependent variable is 'plotted' on the  $y$  axis (ordinate) of the graph.
4. In Graph B, (1) represents a body in free fall and (3) is the 'braking-for-dog' graph.
5. The graph is (most probably) a representation of a body (such as a bullet, or a ball thrown) having been projected vertically with an initial (high) velocity. The velocity is 'eroded' (uniformly) by gravity, until, at the top of the body's path, velocity is briefly zero (where it crosses the  $x$ -axis), and then increases (again uniformly) until it

will (at a time not shown on the graph) re-unite with the ground and very suddenly reach zero velocity again.

### Activity 1.5: Use a ticker timer to measure the rate of acceleration

CLASS (SB p. 14)

#### Guidelines

If your school laboratory has a ticker timer, show it to the class, and explain how it works. You might consider setting the additional task of writing, in their notebooks, and working individually, a brief but carefully worded description of how the apparatus works. You might give the class some ‘specimen’ spacings on the ticker tape, and ask students to identify uniform velocity and uniform acceleration.

### Activity 1.6: Use a pendulum to determine the acceleration of gravity

GROUPS (SB p. 15)

#### Guidelines

Students can work in small groups (depending on the availability of equipment) to make a simple pendulum.

In the first book in this series, it is recommended (in the Teacher’s Guide) that the teacher have made several pendulum ‘bobs’ for activities of this sort. The bobs should be of differing mass, so that students can demonstrate that the mass of the bob does not affect the period of the pendulum. Similarly, it is recommended that the teacher also prepare several lengths of string, with a small loop tied at each end, and again of varying length, so that students can easily assemble pendula having various lengths and masses. Having these small items prepared in advance will greatly facilitate the activity.

Students will very quickly see that the period depends on the length of the string. If you can arrange for a pendulum to hang from an upper storey of the building, the activity will have greater interest, pleasure and teaching impact than simply having a short pendulum swinging unimpressively on a laboratory bench.

### Activity 1.7: Plot two $v-t$ graphs

INDIVIDUAL (SB p. 16)

#### Guidelines

Answers to the questions on the two graphs should to be drawn from the data presented in Tables A and B.

#### Answers

1. Students will be quick to notice that the time of 7.5 minutes is ‘beyond’ the data supplied. Use this to explain (and demonstrate on the board) the method of ‘extrapolation’ – simply by extending the line. By reading the extrapolated line against the ordinate, it is discovered that the velocity at 7.5 minutes is 1.5 m/s. It needs to be assumed, of course, that the relationship between velocity and time remains constant (i.e., in this case, that acceleration is constant). This is justified here, because we are told that this experiment involves a ball falling in a gravity field (the moon’s), and we know that in such situations the acceleration is indeed constant.
2. Had there been no headwind, the only retarding force on the bullet’s velocity would be the friction of the air, which would be motionless relative to the earth with no wind, the air would therefore be moving more slowly, relative to the bullet, than is the case with an oncoming wind. Thus, with no wind (relative to the earth), the ‘braking’ effect of the wind on the bullet’s velocity would be less.
3. The data presented in the graph indicate that the greatest speed of the bullet is 250 m/s. This must necessarily be the speed at which it emerges from the barrel (the ‘muzzle velocity’: see later), because there is no means of the bullet increasing its velocity after leaving the barrel. Thus the length of the barrel has been traversed in 3 milliseconds (three thousandths of one second). The speed of the bullet is, at this point, 250 m/s. Without writing anything down, students should be able to calculate that, if it

travels at 250 m/s, in one thousandth of a second it will travel 0.25 metres (move the decimal point to the left, mentally). Thus in 3 thousandths of a second it will move 3 times 0.25, which equals 0.75 metre. The rifle barrel is therefore about three-quarters of a metre long.

You could point out to the students that this is indeed an acceptable estimate of the barrel length, based on the data given, but that this estimate of the barrel's length is certainly too long. Why? Ask the class. We have assumed that the speed with which it traversed the barrel was 250 m/s, and we based our calculation on that. But in fact the average speed must be less than this, because the bullet started from zero speed at the beginning of the barrel. Thus in the 3 thousandths of a second in which it was travelling through the barrel, it will have moved less than 0.75 m. Therefore the 'real' length of the barrel is less than 0.75 m. Can we apply a better set of arguments, and arrive at a better idea of the barrel's length? Yes. We are told that the bullet moves with constant acceleration along the barrel, thus we were able to draw a straight line for the first 3 milliseconds of the graph. At the end of the barrel, after a time of 3 milliseconds, it has achieved a velocity of 250 m/s. But the average velocity must therefore be 125 m/s. Thus in 1 ms it will

have travelled 0.125 metres, and in 3 ms, 0.375 metre. This is a more 'realistic' (and more valid) calculation of the barrel's length, and it is worth taking the students through the argument carefully.

4. The 'muzzle velocity' is the speed at which the bullet is travelling as it leaves the muzzle. Strictly speaking, of course, 'velocity' requires a direction to be given, because it is a vector. It is understood that the direction is whatever direction the barrel is pointing in, but it would perhaps be better to say the 'magnitude of the muzzle velocity' is so many metres per second.

### How are you doing? (SB p. 17)

Take this opportunity to ask students if there is anything that they do not understand. You can check their understanding by asking them some questions about the information covered in the unit. Explain anything that students do not understand.

### Key words

**acceleration** – the rate of change of velocity with time

**speed** – the rate of change of distance with time

**velocity** – the rate of change of displacement with time

## Practice test: Answers

1. The 'instantaneous velocity' is the velocity at any given instant. It is calculated graphically, from the tangent to the curve (with  $v-t$  axes) at that instant. (5)
2. The 'slope' of a graph is given by the increase in the  $y$ -axis divided by the increase in the  $x$ -axis. Students need to understand that a 'backward', or 'downward' slope is a negative slope. If the value of  $y$  diminishes as the value of  $x$  increases, the slope has a negative value. (8)
3. Students will probably be able to calculate, mentally that the average velocity of the car is 30 km/h, but encourage them to draw the graph and arrive at the answer by the conventional 'graphical' process. Changing to SI units gives 8.33 m/s. (10)
4. d) is correct. (But this of course implies that b) and c) are correct. Students are told to tick only one option.) (2)
5. c) is correct. (2)

**Total mark: 27**

## TOPIC 4: Equations of uniformly accelerated motion

### Performance objectives

- 4.1 deduce the equations of motion from a  $v$ - $t$  graph with initial velocity and constant acceleration
- 4.2 explain the terms used in the equations of motion

## Introduction

This topic introduces the students to kinematics and the use of equations of motion. Although the mathematics involved is simple, some students may have trouble in manipulating the equations to make the required quantity the subject of the equation. The work in this area of physics gives you, the teacher, another opportunity to emphasise to students the importance of competence in mathematics. Particularly those who are interested in the subject, and may be thinking of studying it beyond high school, should realise that competence in mathematics is essential for success in taking their physics to tertiary level.

### Activity 1.8: Calculate how long it takes a body to fall 500 m

INDIVIDUAL (SB p. 21)

#### Guidelines

This is a simple activity, which should involve the whole class, but with all members working individually. The requirement is that they check a calculation by the simple method of successively adding a given value to an increasing amount. Although indeed simple and apparently trivial, the potential benefit of the exercise is to impress upon

them the nature of a constant acceleration, and the fact that they can, if they understand the underlying ideas, check their calculations by elementary arithmetic. We have found that students, both at school and university level, tend to perform calculations on their calculators and write down an answer without any 'mental estimate' of whether the answer is 'reasonable'. Simple errors in calculation – which produce obvious mistakes – are therefore overlooked.

#### How are you doing? (SB p. 23)

Take this opportunity to ask students if there is anything that they do not understand. You can check their understanding by asking them some questions about the information covered in the unit. Explain anything that students do not understand.

#### Key words

**delta ( $\Delta$ )** – from the Greek alphabet; means 'a change in...'

**dynamics** – involved with the movement of bodies; concerned with the physical factors that influence motion

**kinematics** – the mathematical treatment of the paths taken by moving bodies

## Practice test: Answers

1. A 'reaction time' is the time interval between an 'event' and a response by the person (or machine) reacting to it. For example, starter's pistol being fired at the beginning of a race, is an 'event'. It takes a very short time before the athletes respond to the noise of the pistol. The reason why a reaction time always exists, is because it involves such things as the speed at which impulses travel along nerves, the time it takes an impulse to move across the gap (synapse) between one nerve and the next, or between a nerve and a muscle. It also involves the time taken for these impulses to move through parts of the brain or spinal cord. (5)
2. Galileo was born in the 16th Century (1564, specifically). (2)
3. Kinematics – sometimes called 'the geometry of motion' – is the study of movement(s) without considering the forces producing the movements. Acceleration, displacement, time, mass and velocity are the variables used in kinematic problems – as in the 'equations of motion'. Dynamics is the study of the causes of motion. The main variables considered in dynamics are energy, force, mass and momentum. (8)
4. The quantity defined by  $\Delta v$  over  $\Delta t$  is acceleration. In SI units it is measured in newtons (N). (4)
5. A trapezoid is a four-sided figure in which two of the sides are parallel. The formula for the area of a trapezoid is  $\frac{1}{2} \frac{(b^1 + b^2)}{h}$ . Students sketch a trapezoid. (5)
6. During its first second of fall (assuming it is falling towards Earth, and not some other planet, and ignoring air resistance) a body falls 4.9 metres. (2)
7. True (1)
8. a) The distance is 8 m, and we use  $g = 10 \text{ m/s}^2$ . Students should realise that a body starting from rest falls about 5 m in the first second, thus for a distance of 8 m we are 'looking at' a time of a little more than 1 second. It is important that they realise the importance of trying to get a common-sense 'feel' for roughly what the answer is. This avoids uncritical reporting of completely unrealistic answers, which may be simply due to a calculating error.  
Using equation of motion No. 5:  
 $d = v_0 t + \frac{1}{2} a t^2$ .  
 $V_0 t = \text{zero}$ , thus,  
 $d = \frac{1}{2} a t^2$ ,  
Thus,  $8 \text{ m} = \frac{1}{2} 10 \text{ m/s}^2 t$   
Therefore  $\frac{8 \text{ m}}{5 \text{ m/s}^2} = t^2$ ,  
From which  $t = 1.26$  seconds.  
(Students should understand how the units cancel to give a value of seconds.)  
Thus the answer to a) is  
1.26 seconds, or about  
1.2 seconds. (5)
- b) The wind blows at 2 m/s. Because the egg is falling for (about) 1.2 seconds, during its fall it moves  $2 \times 1.2$  metres = 2.4 metres from a point directly beneath the nest. (5)

**Total mark: 37**

## TOPIC 5: Equilibrium of forces

### Performance objectives

- 5.1 distinguish between resultant and equilibrant forces
- 5.2 explain the concept of equilibrium and distinguish between static and dynamic equilibrium
- 5.3 explain the conditions that must be satisfied if a body is to be kept in equilibrium by the action of non-parallel forces
- 5.4 explain what is meant by the moment of a force about a point
- 5.5 explain what is meant by the centre of gravity of a body and identify its position for some regular uniform bodies
- 5.6 name and identify three types of equilibrium with respect to the stability of an object
- 5.7 explain the effect of centre of gravity on the stability of a body
- 5.8 identify the forces acting on a body completely immersed in a liquid and establish the condition for the body to float on the liquid

## Introduction

The conditions for stability are important in a very wide range of situations. The work covered in this topic gives students further practice in working with vectors – specifically vector addition – and leads on to a consideration of flotation, buoyancy and Archimedes' principle.

The subjects covered under this heading provide an abundance of 'everyday' examples for discussion and learning. A 'spontaneous' approach to such problems tends to keep students' interest alive, because they are likely to identify with these 'ordinary' applications of physical principles.

### Activity 1.9: Find the centre of gravity on a flat body of irregular shape

PAIRS OR SMALL GROUPS (SB p. 28)

#### Resources

Each group will need a piece of stiff cardboard about the size of an A4 page, a plumb line, pencil, and a conveniently situated nail or peg in a vertical surface from which to hang their plumb line and three or four pairs of scissors.

#### Guidelines

Point out that students use a pendulum for the plumb line. A 'plumb line' is simply a pendulum which is not swinging (oscillating): it is pointing towards the centre of the earth.

Ask students what plumb lines are used for. Builders and carpenters make extensive use of plumb lines. Convey to the students that the word 'plumb', with a silent 'b' is not the same as a 'plum'.

### Activity 1.10: Calculate how much helium is needed in a balloon

INDIVIDUAL (SB p. 32)

#### Guidelines

The procedure involves finding the total mass of equipment to be lifted – in this case 130 kg. This is converted to a force by multiplying by 9.8. This is 1 274 newtons. The density of helium is 0.00017 kg/ℓ, and that of air is 0.001 kg/ℓ at the same temperature and pressure. Thus a given volume of helium has about  $(0.00017 \text{ divided by } 0.001) = 0.17$  times the mass of the same volume of air under the same conditions of temperature and pressure. This proportionality is of course the same as the proportionality between the forces (weights) exerted by the two fluids.

We now need to calculate the volumes of air and helium such that the difference between their weights will be equal to a weight of 1 274 newtons. This is the weight the helium will be required to lift. This is now simple proportionality. One thousand litres of helium displaces 1 000 litres of air. The 'upthrust' of the air on the helium will be equal to the weight of the air displaced, less the weight of the helium itself. One

thousand litres of air has a mass of 1 kg, and therefore weighs 9.8 newtons.

From the proportionality worked out above, 1 000 litres of helium weighs 0.17 times this, thus it weighs 1.66 newtons. (In effect this means that it would have this weight in a vacuum.) The difference between the weight of the helium and the weight of the air is therefore 8.14 newtons. This is the effective ‘upthrust’ provided by every 1 000 litres of helium in air.

But our student requires an upthrust of at least 1 274 newtons. Thus she needs  $1\,000 \times 1\,274/8.14$  litres of helium. This comes to 156 500 litres (rounded off to the nearest 100) of helium. That is equal to 156.5 cubic metres of the gas.

### How are you doing? (SB p. 32)

Take this opportunity to ask students if there is anything that they do not understand. You can check their understanding by asking them some questions about the information covered in the unit. Explain anything that students do not understand.

### Key words

**buoyancy** – the force that causes objects to float

**centre of gravity** – the point inside the body at which all of its weight appears to be concentrated

**couple** – a pair of forces, equal in magnitude and opposite in direction, and not lying along the same line

**moment** – is a combination of a physical quantity and a distance. The moment of a force is a measure of its tendency to cause a body to rotate about a specific point or axis

**torque** – the turning force caused by a couple

**upthrust** – the force that pushes an object up and makes it seem to lose weight in a fluid

## Practice test: Answers

1. Sketch B represents the hot water. Hot water is less dense than cold water, thus more of it needs to be displaced by the boat to equal the weight of the boat. Thus the boat floats lower in the hot water. (5)
2. An equilibrant force is one which, when added to a system which is not in equilibrium, produces a state of equilibrium. (5)
3. The man floating with more of his head out of the water is the fat one. Fat is less dense than muscle, so his body is less dense than the thin, muscular person's body. In the fat man's case there will therefore be a greater difference between the weight of water he displaces and his own body weight, than in the case of the thin man. Thus there is a greater upthrust on the fat man's body than on the thin (muscular) man's body. Thus the fat man floats 'higher' in the water. (4)
4. It will float at the same level. The moon's gravitational 'pull' is much less than Earth's, but remember that this difference affects all relevant forces in the same proportion: the weight of the boat, the weight of the displaced water, and the 'upthrust'. The fact that the moon's gravity on its surface is only about one sixth of that at Earth's surface is irrelevant. (5)
5. Yes. The density of lead is  $11.3 \text{ kg}/\ell$ . The density of mercury is  $13.5 \text{ kg}/\ell$ . The less dense body floats in the more dense fluid. (2)
6. No. Petrol is less dense than water, thus petrol will float on water – and will continue to burn. (2)
7. The vector sum of all forces acting on the body must be zero; the sum of the torques acting on a body must be zero. (4)
8. The moment arm on your sister's side of the see-saw must be twice the length of the moment arm on your side. In other words she must be sitting twice as far from the fulcrum as you are, so that the product force  $\times$  moment arm on one side of the fulcrum is equal to the product force  $\times$  moment arm on the other side of the fulcrum. (5)
9. The ship must use a significant amount of fuel in a 500 km journey. Most of the breakdown products are released into the environment, thus the vessel is lighter at the end of her run. (2)
10.  $10 \text{ kg} \times 1.2 \text{ m} = 0.65 \text{ m} \times x \text{ kg}$ , therefore  $10 \times \frac{1.2}{0.65} = 18.4 \text{ kg}$ . Thus the joint of meat has a mass of 18.4 kg. (Again, students should realise that this is close to what they should expect from a simple evaluation of the problem. The meat is a little more than half the distance (1.2 m) of the balancing mass from the fulcrum, thus it should be just a little less than twice the mass of the 10 kg mass.) (5)

**Total mark: 39**

## Topic 6: Projectiles

### Performance objectives

- 6.1 identify a projectile motion
- 6.2 derive the range, maximum height and time of flight of a projectile

## Introduction

This topic gives students more examples of vector analysis and practice in calculation. The main generality to convey to the students is that the behaviour of a projectile can be treated as two ‘independent’ movements: those in the  $x$ - and  $y$ -axes. Furthermore, if we ignore friction, speed in the  $x$ -axis may be treated as constant.

### Activity 1.11: Do research on Jules Verne

INDIVIDUAL (SB p. 37)

#### Guidelines

The book *From the Earth to the Moon* deals with a group of people who reach the moon by being fired from a massive cannon – thus they would need to reach ‘escape velocity’. (No cannon can achieve this, and if it could, the occupants would be killed on departure.)

### Activity 1.12: Observe and time trajectories of projectiles

PAIRS OR SMALL GROUPS (SB p. 41)

#### Guidelines

Students use a catapult to shoot pebbles at various angles to the ground. Observers

attempt to sketch the trajectories and use a stopwatch (or watch with a second hand) to see how long some of the pebbles remain airborne.

### How are you doing? (SB p. 41)

Take this opportunity to ask students if there is anything that they do not understand. You can check their understanding by asking them some questions about the information covered in the unit. Explain anything that students do not understand.

### Key words

**ballistics** – the study of projectiles

**parabola** – a two-dimensional, mirror-symmetrical curve, which is approximately U-shaped

**range** – the distance to which a projectile is or may be sent by a weapon

**trajectory** – the path of a projectile as it moves

## Practice test: Answers

1. A 'symmetrical trajectory' means that the time to reach maximum height, from a ground launch, is equal to the time to travel from that point back to ground level. Similarly, neglecting air resistance, maximum height is reached half way between launch and landing, provided both are at the same level. (4)
2. The path of a projectile is not a parabola when it is projected straight up or straight down. (2)
3. The ball starts at 20 m/s. During the first second of upward flight, gravity will knock approximately 10 m/s off its speed. This will leave it with a 'residual' upward speed of about 10 m/s. This will be removed in the second second. Thus it will move upwards for about 2 seconds, and will reach a height of about 20 metres. Because the flight will be symmetrical, the ball will be moving for about 4 seconds. (5)
4. Galileo showed that projectile motion can be analysed as two separate motions: a vertical motion, under the influence of the acceleration due to gravity, and horizontal motion at constant speed (if we ignore air resistance). (5)
5. Ballistics. (2)
6. 'Escape speed' is the upward speed a body needs to have in order to leave Earth's gravitational 'pull' – and thus never to come down again. For Earth the escape speed is about 11.2 km/s (if we ignore the frictional 'drag' of the atmosphere). (5)
7. Answers will vary. (2)
8. 45 degrees. (2)
9. In the story by Jules Verne, his characters travelled from Earth to the moon by being fired from a massive cannon, thus 'escape velocity' would need to have been attained. (2)
10. b) is correct. (2)

**Total mark: 31**

## TOPIC 7: Simple harmonic motion

### Performance objectives

- 7.1 define simple harmonic motion
- 7.2 show the relationship between linear and angular speed, and linear and angular acceleration
- 7.3 show the relationship between period and frequency
- 7.4 calculate the energy in the system
- 7.5 explain forced vibration and resonance

## Introduction

Simple harmonic motion – ‘SHM’ – develops the concept of repetitive motion about an equilibrium position, and it introduces the student to a very wide range of physical phenomena which involve this sort of movement. You should tell your students that, if they intend taking their studies in physics beyond high school, they will certainly use the principles of SHM in a diversity of interesting situations.

### Activity 1.13: Investigate harmonic motion

GROUPS (SB p. 43)

#### Guidelines

The first activity in the topic can be done as a ‘thought experiment’, in which case it should be conducted – ‘mentally’ – with the whole class. If it is to be performed as a ‘real’ exercise, it may be done as a demonstration for the whole class, or, if apparatus allows, it can be done by small groups. Each set will require a long, thin spring with an appropriately sized mass attached to one end, and a hook at the other end for hanging the system on a convenient peg or nail. Ensure that students are aware of the idea of an ‘equilibrium position’ before the system is put into oscillation, and that the equilibrium position represents the lowest energy level of the system.

### Activity 1.14: Demonstrate the natural (resonant) frequency of glass

INDIVIDUAL OR PAIRS (SB p. 48)

#### Resources

Six to eight wine glasses

#### Guidelines

The ‘wine glass demonstration’ is suitable for class demonstration, small groups, pairs or individuals. It may be difficult to provide enough glasses for each member of the class to work independently. If you provide six to eight glasses, all of which you have tested for their appropriateness, each member of the class will have an opportunity to achieve the resonance effect. It takes only a minute or two to accomplish the necessary movements.

Many different shapes of glass will produce an audible resonance when a moistened finger is run around the lip of the glass. We have found that wine glasses are generally good. Because not all glasses will produce the effect, it is desirable that you test the glasses yourself before giving them to the class.

#### How are you doing?

(SB p. 51)

Take this opportunity to ask students if there is anything that they do not understand. You can check their understanding by asking them some questions about the information covered in the unit. Explain anything that students do not understand.

### Key words

**angular velocity** – the rate of change of angular displacement

**damped oscillations** – when oscillations become less and eventually stop

**dissipative force** – force of such nature that energy is lost from a system when motion takes place

**elasticity** – the property by which a body recovers its original size or shape after a deforming force has been removed from it

**natural period** – period of an oscillator that is dependent on the properties of the system itself: its mass and its spring constant

**resonance** – when one object vibrating at the same natural frequency of a second object forces that second object into vibrational motion

## Practice test: Answers

1. 'Elasticity' is the tendency or ability of a material to return to its original shape and/or dimensions after a deforming force has been removed from it. (2)
2. Simple harmonic motion is that vibratory motion in which the acceleration is proportional to the displacement and always directed towards the equilibrium position. (4)
3.  $F = kx$  (4)
4. The period ( $T$ ) of a periodic motion is the time taken to complete one 'cycle' of the repeated activity. The frequency is the reciprocal of the period, i.e.  $\frac{1}{T}$ . (4)
5. The swing of a pendulum is not 'perfect' or 'ideal' SHM because the movement of the bob, at any instant in its swing, is tangential to the curve of the swing, and thus not directed at the equilibrium position. (4)
6. For small amplitudes of oscillation, however, the movement is very close to SHM, and is often accepted as being an example of SHM. (4)
7. Angular speed is the rate of change of angle, in a rotational movement – as in a turning wheel. It is the angle turned through per unit of time. (2)
8. The acceleration vector is directed towards the centre of the circle. (2)
9. The wheel rotates through a total of  $360 \times 40$  degrees in one minute = 14 400 degrees. Students must give the answer in seconds (because this is the SI unit of time), thus it turns 14 400 divided by 60 = 240 degrees per second (5)
10.  $T = 2.00$  seconds. Students use the formula for the period ( $T$ ) of pendulum on page 46 of the Student's Book. (5)

**Total mark: 32**

## TOPIC 1: Linear momentum

## Performance objectives

- 1.1 state and explain in your own words the meaning of ‘laws of motion’
- 1.2 show graphically:
- the relationship between the accelerations produced by a given set of forces acting on a single body
  - the relationship between the accelerations produced by a constant force on varying masses
  - know that the results from (a) and (b) lead to the equation  $F = ma$
- 1.3 solve simple problems based on Newton’s laws of motion and the principle of momentum
- 1.4 state and explain the meaning of the law of conservation of linear momentum
- 1.5 solve simple problems involving the conservation of linear momentum
- 1.6 explain:
- **why** walking is possible
  - **why** a gun recoils when fired
  - **how** a rocket is propelled
  - **how** a jet plane is propelled
- 1.7 explain inertial mass and the relationship between mass and weight
- 1.8 explain why the weight of a body may vary from place to place

## Introduction

In this topic we introduce Newton’s laws of motion, and thus deal with some of the most fundamental, best-known and most powerful laws in physics. They need to be discussed and carefully translated into concrete mathematical examples, so that students have an opportunity to appreciate the intellectual breadth of the generalisations embodied by the laws.

It will be necessary to ensure that students learn the wording of the laws. Take care however, as in all other areas of physics, to see that, as far as is possible, all students have a genuine understanding of what the laws convey.

## Activity 2.1: Draw a vector analysis and investigate collisions

INDIVIDUAL OR PAIRS (SB p. 59)

## Guidelines

1. A vector analysis of the example given by two balls is a simple exercise, involving skills with which all the students should be familiar. Each student should do the analysis in his or her notebook, and should be able to complete the task without help.
2. This activity involves ‘frictionless trolleys’, which are not available in all school science facilities. If your school does not have such a set of trolleys, you can run the exercise as a ‘thought experiment’ involving the whole class. It is easy to imagine trucks on a

straight, horizontal railway track. The requirement is that the trucks move without friction, and this idea can be conveyed carefully, emphasising that friction ‘drains away’ precisely the mechanical energy that is otherwise conserved.

3. Following from point 2 above, it involves no excessive demands on imaginative capacity to require students to picture trucks bumping into each other, and either bouncing apart after the collision, or ‘sticking together’. These represent ‘elastic’ and ‘non-elastic’ collisions respectively.

### Activity 2.2: Demonstrate the principle of rocket propulsion

PAIRS (SB p. 61)

#### Guidelines

This is a ‘fun activity’, but it is quite sufficiently instructive as to make it worth doing. Students work in pairs or small groups. Each group requires one or two rubber balloons. You may decide to add minor ‘variants’ by suggesting to the students that, having experimented with simply releasing their inflated balloons, and observing the erratic course followed by these small air-powered rockets, they may want to attach a length of string or ribbon behind the ‘exhaust’

of the rocket/balloon, to observe whether this stabilises its flight. If so, provide lengths of string or ribbon, and a pair of scissors.

If you decide to add this small ‘embellishment’, you might suggest to the students that they look up in their dictionaries, and record in their notebooks, the meaning of the word ‘drogue’.

#### How are you doing? (SB p. 66)

Take this opportunity to ask students if there is anything that they do not understand. You can check their understanding by asking them some questions about the information covered in the unit. Explain anything that students do not understand.

#### Key words

**atmospheric pressure** – the force per unit area exerted against a surface by the weight of the air above that surface

**impulse** – a change in momentum; a vector quantity; the impulse applied to a body is equal to the change of momentum experienced by the body

**inertia** – the property of a body which causes it to resist any change in its motion

**pascal** – the SI unit of pressure (Pa)

## Practice test: Answers

1. NASA = 'National Aeronautics and Space Administration'. (5)
2. Newton's third law states that 'For every force that acts on one body, there is a second force equal in magnitude, but opposite in direction, that acts on another body.' (4)
3. In the case of the second egg the deceleration happens over an extended time, thus the effective force of the collision is far less. This egg is likely to survive intact. (5)
4. The principle is the same as in the case of the cushioned egg. Bending your legs on landing extends the time over which the force acts, thus reducing the magnitude of the force. (4)
5. Pressure = force per unit area. The SI unit of pressure is the pascal (Pa). One pascal is a force of one newton acting on an area of one square metre. (4)
6. Seat belts increase the area over which force is applied to the body during a collision, thus the pressure is 'distributed' and made less damaging. Also, the amount of time taken to bring the body to rest is extended, thus the force is reduced. (5)
7. A rocket carries not only its fuel supply, but also the substance necessary to 'burn' (oxidise) the fuel. Thus a rocket can operate in a vacuum. A jet draws in air from the surroundings, heats and pressurises it, and forces the gases out of its exhaust system. A jet uses the surrounding air for propulsion, and also for burning its fuel. It cannot operate in a vacuum. (4)
8. Gravitational mass is the mass we measure by measuring the force with which local gravity 'pulls' the mass (i.e. we measure the body's weight), and converting the force to a mass by using an appropriate factor – such as 9.8 in the case of bodies on or near the surface of the earth. 'Inertial mass' is measured by determining the amount of force needed to give a certain acceleration to a body. The relationship between mass, force and acceleration is given by Newton's second law:  
force = mass  $\times$  acceleration. (5)  
This is the way of determining a body's mass in deep space, where there is no gravity field strong enough to provide the 'pull' of weight. Physicists have deep reasons for believing that there is no difference between 'inertial mass' and 'gravitational mass'.
9. Remember that gravity 'behaves' as if the source of a body's gravity is buried in the centre of the body: its centre of gravity. In the case of planets and satellites, the 'pull' of the body's gravity 'comes from' the centre of the body. Remember also that the further we are from a source of gravity, the weaker is the gravity field. Now, on the surface of Earth we are some distance from the earth's 'centre of gravity'. The radius of the earth is 6 371 km. If we go up a mountain, the force of gravity there is less, because we are further from earth's centre of gravity. The moon is very much smaller than Earth. Its radius is 1 737 km. Thus on the surface of the moon we are very much closer to its centre of gravity than we are to Earth's centre of gravity when we are on the Earth's surface. For this reason the moon's gravity field, at its surface, has been less 'diluted' or 'weakened' by distance from its centre than has Earth's. Therefore, although the moon has only about one eightieth of the mass of Earth, the strength of its gravity at its surface is about one sixth of the strength of Earth's gravity at its own surface. (4)

**Total mark: 40**

## TOPIC 2: Mechanical energy

### Performance objectives

- 2.1 calculate the kinetic and potential energy of a body
- 2.2 verify conservation of energy principles and show that the total energy is conserved for a given set of data on the energy of a particle in a conservation field
- 2.3 define a machine and list at least five simple machines
- 2.4 define and calculate:
  - a) force ratio
  - b) velocity ratio
  - c) efficiency for a simple machine, and write the mathematical relationship between a), b) and c)
- 2.5 state how friction can be reduced in the moving parts of a given machine
- 2.6 perform a simple experiment using a spring balance to determine the coefficient of friction between two surfaces

## Introduction

Students have already learnt something about mechanical energy, so they will be familiar with the ideas presented here. You need to carefully discuss the concept of a 'conservation field' or a 'conserved force', because some of the ideas, although not 'difficult', are perhaps not intuitively obvious. This should be seen as a positive challenge, because of the pleasure experienced when understanding dawns.

### Activity 2.3: What do you remember about mechanical energy?

INDIVIDUAL (SB p. 67)

#### Answers

1. Provided that energy is not lost due to friction, the sum of kinetic and gravitational potential energies is conserved, and is therefore constant.
2. Gravitational potential energy and kinetic energy.
3. Students should name and draw a simple pendulum.
4. A reference level in this context is the level at which the gravitational potential energy is defined to be zero.
5. The unit is the joule (J). It is defined as 1 Nm (one newton-metre), or  $1\text{kg}\cdot\text{m}^2/\text{s}^2$ .

### Activity 2.4: Measuring the coefficient of friction between two surfaces

SMALL GROUPS (SB p. 77)

#### Guidelines

In this activity it is important that the force pulling the spring along the surface is parallel to the surface and in the same line as the direction of movement of the block. Then the coefficient of friction (dynamic friction in this case) is: the force recorded on the spring (in newtons) divided by the force 'normal' to the surface. This 'normal' force is simply the weight of the block, and thus is the mass of the block (in kg) multiplied by  $g$ , which is 9.8 metres per second squared.

#### How are you doing?

(SB p. 79)

Take this opportunity to ask students if there is anything that they do not understand. You can check their understanding by asking them some questions about the information covered in the unit. Explain anything that students do not understand.

### Key words

**conservative force** – forces that act on an object and do not cause any energy loss in the system

**dissipative force** – forces of such nature that energy is lost from a system when motion takes place

**fulcrum** – the point on which a lever rests or is supported and on which it pivots

**mechanical advantage** – the ratio of the force applied to one end of the lever (the input force) to the force delivered at the other end of the lever (the output force)

**velocity ratio** – (in a lever) the ratio of the lengths of the lever arms

## Practice test: Answers

1. The formula is:  $KE = \frac{1}{2}mv^2$ . (4)
2. A machine is a device that converts energy into work. Alternatively, a machine is a device for using force. (2)
3. Simple machines: lever; wheel and axle; inclined plane; wedge; screw; pulley. (Any four) (4)
4. Orders of lever: Class 1, e.g. 'crowbar': fulcrum is between load and effort. Class 2, e.g. wheelbarrow: load and effort are on the same side as the fulcrum. Class 3, e.g. forceps ('tongs'): effort is between the fulcrum and the load. (4)
5. An Archimedes screw (Archimedean screw) is used to move water or watery material from a lower to a higher level. It works on the same principle as a mincer. The mincer has a screw, with a large flange, which, when rotated, drives material along a pipe. In the case of the ordinary Archimedean screw, the flange of the screw makes watertight contact with the inside surface of the barrel, so that water is moved along the barrel without significant amounts of leakage. (5)

**Total mark: 19**

## TOPIC 3 (A): Heat energy: Temperature and its measurement

### Performance objectives

- 3.1 construct a device for measuring the temperature of a body
- 3.2 use the variation of:
  - a) pressure of a gas with temperature
  - b) the expansion of a solid, liquid or gas with temperature
  - c) electrical resistance of a material to measure the temperature of a body
- 3.3 distinguish between heat and temperature and between temperature points and temperature intervals
- 3.4 select those liquids which are suitable for use in liquid-in-glass thermometers from a given list of liquids and their properties
- 3.5 state the instrument used for measuring temperature
- 3.6 explain the device for measuring the temperature of an environment
- 3.7 describe the absolute scale of temperature and explain the meaning of the absolute zero of temperature
- 3.8 convert a given temperature on the Celsius scale to a temperature on the Kelvin scale
- 3.9 describe the kinetic molecular model of temperature

## Introduction

This topic is about temperature and thermometers. Revise the concepts that your students were taught about temperature and thermometers in SS1. Differentiate between heat and temperature by referring to the example in the SB text. The four different types of thermometers which use different thermometric substances are discussed in some detail. The calibration of the thermometers forms an important part of the learning, and the calibration process for all besides the thermocouple are similar because the relationship between changes in temperature and the changes in the thermometric substance is linear. The two important points used for calibration are the melting and boiling points at an atmospheric pressure of 760 mm Hg. The students should be able to give the advantages and disadvantages of each of the different types of thermometers. They should also be able to list the properties required by a liquid to be used in a liquid-in-glass thermometer. The topic is concluded by a brief introduction to the kinetic molecular theory of gases.

## Activity 2.5: Construct a liquid-in-glass thermometer

GROUPS (SB p. 81)

### Resources

An empty biro tube from a ball-point pen, screw-top plastic pill bottle, alcohol, water, red food colouring, silicone adhesive, oil, felt pen, ice and water, boiling water and a sharply pointed nail

### Guidelines

If the school has sufficient narrow-bore capillary tubes, and if you, the teacher are proficient in cutting capillary tubes and in glass-blowing, you could make more efficient thermometers using these tubes. The following website shows how liquid-in-glass thermometers are manufactured: <https://www.youtube.com/watch?v=SZvAmvGQKEA>.

An alternative method of constructing a liquid-in-glass thermometer is found at <https://www.youtube.com/watch?v=w1h3y4oSsnk>. Biro tubes are the insides of ball-point pens. The tube must be clean of all ink, which can be done by soaking the tube in warm dishwashing liquid.

You can use drinking straws instead of biro tubes, but the wider diameter of the straw makes the thermometer more inaccurate. This is because the volume expansion of a cylindrical-shaped liquid is given by  $\Delta V = \Delta A \times \Delta h$ . For a given increase in volume, the larger the cross-sectional area, the smaller the increase in the height of the liquid. Thus small increases in temperature are difficult to read on thermometers of relatively large cross-sectional area.

### Answers

13. Some probable answers to step 13 of this activity are:

- The diameter of the biro tube is larger than that of a regular thermometer, and this results in less accurate height readings.
- The liquid used in the biro tube is a mixture of alcohol and water, and water does not expand as well as pure alcohol or mercury.
- The biro tube may not have a uniform cross-sectional area.
- The plastic of the tube will also expand, and this expansion may be greater than that of the glass of a regular thermometer.
- The glass in regular thermometers acts as a magnifier, enabling greater accuracies in reading, whereas plastic does not.
- Some of the expansion of the liquid also takes place in the pill bottle, which affects the expansion in the tube.

### Activity 2.6: Construct a resistance wire thermometer

GROUPS (SB p. 88)

#### Resources

Two AA batteries and a battery holder, about 0.3 m of platinum wire, 16 mm × 100 mm heat-resistant glass test tube, two-holed rubber stopper to fit test tube, 15 mm × 80 mm wooden dowel stick, ammeter, voltmeter, thermometer, connecting leads, silicone

adhesive, ice, water, Bunsen burner, beaker, wire gauze and a tripod stand

### Guidelines

The important features of this activity are:

- You need an insulating cylindrical core on which to wind the resistance wire (you could use copper wire instead of platinum).
- The windings must not touch each other (if the wire is insulated, this is not a problem).
- The wound wire and core must be enclosed in a watertight container which can withstand the temperature of boiling water or the heat from a Bunsen burner.

### Answers

13. Use the equation  $R = \frac{V}{I}$  to calculate the resistance from the meter readings.
14. The graph of  $R$  vs  $T$  is linear because the temperature and resistance are related by the equation  $R = R_0[1 + \alpha(T - T_0)] = \alpha R_0 T + R_0$  if  $T_0 = 0^\circ\text{C}$ . The constant  $\alpha$  is the temperature coefficient of resistance ( $0.0038^\circ\text{C}^{-1}$  for platinum and  $0.0039^\circ\text{C}^{-1}$  for copper).

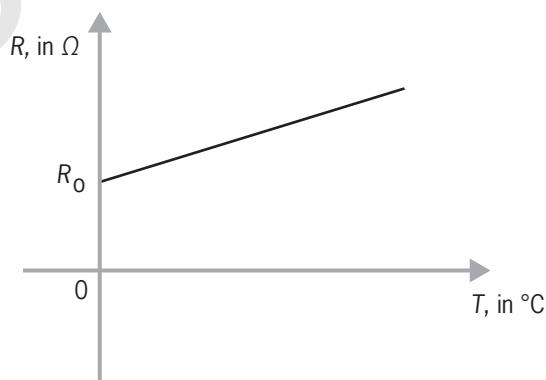

15. Some possible answers to Step 15:

- The temperature of the resistance wire may not be the same as that of the water in the beaker. (Some of the heat from the water may be absorbed by the test tube, the air in the test tube and the dowel stick.)
- Inaccuracies in the readings of the ammeter and voltmeter.
- Inaccuracies in the readings of the graph.

## Activity 2.7: Construct a simple thermocouple thermometer

GROUPS (SB p. 90)

### Resources

A digital multimeter, single-strand insulated copper wire, 50 mm length of insulated constantan wire, ice and water, beaker, cigarette lighter (or any source of flame) and connecting leads

### Guidelines

If you do not have constantan wire, you could use iron wire or nichrome or any other wire (but you will need thermocouple tables for these wires.) A digital voltmeter (or multimeter) is used in this activity because of the very small currents generated.

You will find a conversion table for a copper-constantan thermocouple at the website [www.intech.co.nz/Products/temperature/typet](http://www.intech.co.nz/Products/temperature/typet). According to the table the voltmeter reading is 0 for a temperature of 0 °C and 0.992 mV at a room temperature of 25 °C.

### How are you doing? (SB p. 96)

Take this opportunity to ask students if there is anything that they do not understand. You can check their understanding by asking them some questions about the information covered in the unit. Explain anything that students do not understand.

### Key words

**absolute temperature** – temperature measured on the Kelvin scale

**absolute zero** – (0 K or -273 °C) the lowest possible temperature at which point the atoms of any substance have minimal motion

**boiling point** – the temperature at which a liquid boils and turns to vapour

**calibrate** – to make a precise measurement

**Celsius scale** – the scale of temperature in which water freezes at 0° and boils at 100° under standard conditions

**clinical thermometer** – small medical thermometer with a short but finely calibrated range for taking a person's temperature

**constant-volume gas thermometer** – a very accurate thermometer used in calibration of various other thermometers

**ideal gas law** – this law takes into account changes in all of pressure, volume and temperature of a gas; also called the general gas law

**Kelvin scale** – a scale of temperature with absolute zero as zero, and the triple point of water as exactly 273.16 degrees

**kinetic molecular theory** – the theory shows how individual gas particles interact with one another

**liquid-in-glass thermometer** – thermometer that utilises the variation in volume of a liquid in temperature

**manometer** – an instrument that uses a column of liquid to measure pressure

**maximum and minimum thermometer** – a thermometer that records the highest and lowest temperatures reached during a period of time

**melting point** – the temperature at which a given solid will melt

**pressure (gas)** – the force that the gas exerts on the walls of its container

**pressure law** – for a fixed mass of gas, at a constant volume, the pressure ( $p$ ) is directly proportional to the absolute temperature ( $T$ )

**resistance thermometer** – also called resistance temperature detectors (RTDs) – sensors used to measure temperature by correlating the resistance of the RTD element with temperature

**Seebeck effect** – a phenomenon in which a temperature difference between two dissimilar electrical conductors or semiconductors produces a voltage difference between the two substances

**thermocouple** – a sensor used to measure temperature

**thermometer** – device that measures temperature or a temperature gradient

**thermometric substance** – the material used in the thermometer, whose property varies with temperature



## TOPIC 3 (B): Heat energy: Heat energy measurements

### Performance objectives

- 3.1 explain the relationship between the heat supplied to a substance, and:
  - a) its temperature change at a constant mass
  - b) its mass at a constant temperature change
- 3.2 explain the terms specific heat capacity and thermal capacity
- 3.3 explain why there is an unequal rise in temperature for different substances of the same mass supplied with the same quantity of heat
- 3.4 calculate unknown quantities using the relation  $Q = mc\Delta T$  when no change of state is involved
- 3.5 determine the melting point of a solid and boiling point of a given liquid
- 3.6 list the effects of impurities and pressure on the melting of a solid and boiling point of a given liquid
- 3.7 solve simple problems involving latent heat
- 3.8 distinguish between evaporation and boiling and explain sublimation
- 3.9 explain the working experiences of such common devices as:
  - refrigerator
  - air conditioner
  - pressure cooker
- 3.10 explain the effects of humidity on personal comfort

## Introduction

This topic focuses on calorimetry and state changes. The important concept of specific heat capacity is first introduced. Since specific heat capacity is dependent on changes in temperature and not on the actual temperature, the units used for temperature could be either °C or K. We use the former in this textbook. We also use the more correct approach of solving calorimetry problems using conservation of energy instead of ‘heat lost = heat gained’.

### Activity 2.8: Determine the specific heat capacity of water

GROUPS (SB p. 103)

#### Resources

Two polystyrene foam cups, sheet of polystyrene foam, piece of nichrome wire, a 6 V battery, connecting leads, thermometer, metal stirrer, stopwatch, voltmeter, ammeter, rheostat, switch, graph paper and a mass balance

#### Guidelines

You may prefer to use copper calorimeters, if these are available, instead of polystyrene

foam cups. The use of the polystyrene foam cups avoids the extra step of calculating the heat gained by the copper calorimeter. When using the polystyrene foam cups, make sure that the heating coils do not make contact with the cups, which could result in the cups melting with large currents. Choose about 200 ml of water and determine the right amount of resistance and current to use with the power supply that you have available so that you can get appreciable increases in temperature in the two-minute time intervals. This must be done before the students do the experiment. To prevent heat losses to the surroundings, the temperature increases must not be too large or too low.

#### Answers

19. Errors that may occur are: heat in the calorimeter not distributed evenly, some heat gained by the stirrer, current and voltage not being kept constant, some heat may have been lost to the surroundings.

### Activity 2.9: Determine the specific heat capacity of a block of metal

GROUPS (SB p. 105)

#### Resources

Two polystyrene foam cups, one polystyrene foam lid, thermometer, metal block, metal stirrer, beaker of water, wire gauze, tripod stand, Bunsen burner, wooden tongs, cold water (about 16 °C) and a mass balance

#### Guidelines

As for Activity 2.8, you may opt to use copper calorimeters for this activity. The mass of the metal block may be determined before heating it or after heating, as done in the text.

#### Answers

8. We use cold water so that the heat lost to the surroundings when the system is above room temperature is balanced by the heat taken in from the surroundings when the system is below room temperature.
14. Errors that may occur are: heat in the calorimeter not distributed evenly, some heat gained by the stirrer, the temperature of the block of metal may decrease while the metal is being transferred from the hot water to the calorimeter, some of the hot water from the beaker may be transferred to the calorimeter, some heat may be lost to the surroundings.

### Activity 2.10: Determine the specific latent heat of fusion of ice

GROUPS (SB p. 108)

#### Resources

Nested polystyrene foam cups with lids, thermometer, ice cubes in insulated container, electric kettle, absorbent paper and a mass balance

#### Guidelines

You should determine the correct amount of ice cubes to use prior to the student activity.

#### Answers

1. We use warm water so that the heat lost to the surroundings when the system is above room temperature is balanced by the heat taken in from the surroundings when the system is below room temperature.
2. Errors that may occur are: heat in the calorimeter not distributed evenly, the ice may not be dry and may have water clinging to it, the final temperature may not be constant, some heat may be lost to the surroundings.

### Activity 2.11: Determine the specific latent heat of vaporisation of water

GROUPS (SB p. 109)

#### Resources

Nested polystyrene foam cups with three-holed lids, thermometer, boiling flask, retort stand, wire gauze, Bunsen burner, bent delivery tube, hook-shaped delivery tube, water (steam) trap, rubber stopper, lagging (cotton wool) and a mass balance

#### Guidelines

If your school has a steam generator, shown below, you can use it instead of the apparatus shown in the student text.

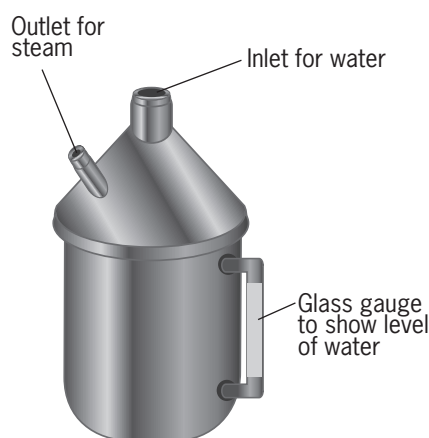

A water trap is essential to ensure that only dry steam enters the calorimeter. Make the students aware of the dangers of steam burn when conducting this activity.

In step 4 in order to prevent an overflow of water in the calorimeter, after the steam condenses, do not pass too much steam into the calorimeter.

### Answers

1. The lagging prevents the steam from condensing on the sides of the delivery tube.
17. Some errors may be: heat in the calorimeter not distributed evenly, some heat gained by the stirrer, some water entering the calorimeter together with the steam, the final temperature not being constant, the temperature of the steam not being 100 °C, some heat lost to the surroundings.

### Activity 2.12: Determine the heating and cooling curve of naphthalene

GROUPS (SB p. 112)

#### Resources

A hard-glass test tube, a thermometer, naphthalene crystals, stop watch, Bunsen burner, retort stand, a beaker, water and graph paper

#### Guidelines

You could use a hotplate instead of a Bunsen burner for this activity. Do not leave the thermometer in the test tube of molten crystals when the temperature is below 25 °C because the thermometer will get stuck in the solid crystals when the naphthalene cools. The graph below shows some typical results for the cooling curve for this experiment.

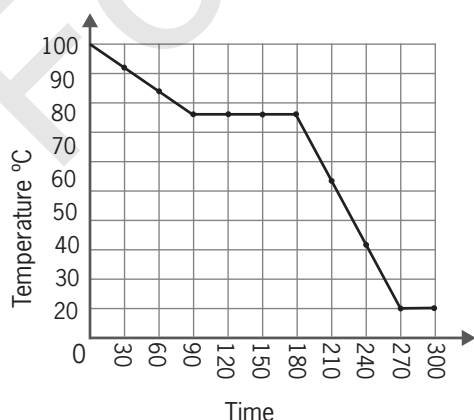

The following website gives a demonstration of how to determine the melting point of naphthalene: <https://www.youtube.com/watch?v=t8vFW56ZrRI>.

### Activity 2.13: Investigate evaporation

PAIRS OR GROUPS (SB p. 116)

#### Resources

A small beaker or watch glass, ether, small glass slab or ceramic tile and a drinking straw

#### Guidelines

You could use alcohol or methylated spirits instead of ether in this activity.

The following website gives a good explanation of evaporation and cloud formation: [www.youtube.com/watch?v=wagrbfKV5bE](http://www.youtube.com/watch?v=wagrbfKV5bE).

#### How are you doing?

(SB p. 121)

Take this opportunity to ask students if there is anything that they do not understand. You can check their understanding by asking them some questions about the information covered in the unit. Explain anything that students do not understand.

#### Key words

**condensation point** – the temperature at which a material changes from a gas to a liquid; the same as the boiling point

**cooling curve** – a line graph that represents the change of phase of matter, typically from a gas to a solid or a liquid to a solid

**dew** – water in the form of droplets that appears on thin, exposed objects in the morning or evening due to condensation

**dew point** – the temperature at which dew forms and which is a measure of atmospheric moisture

**evaporation** – the process by which water is converted from its liquid form to its vapour form

**freezing point** – the temperature at which a liquid turns into a solid when cooled

**heat capacity** – the amount of heat required to raise the temperature of an object or substance one degree

**heating curve** – plot of the temperature versus time

**latent heat of condensation** – energy released when water vapour condenses to form liquid droplets

**latent heat of fusion** – the heat absorbed as a substance changes phase from liquid to solid

**latent heat of solidification** – heat liberated by a unit mass of liquid at its freezing point when it solidifies

**relative humidity** – the amount of water vapour present in air expressed as a percentage of the amount needed for saturation at the same temperature

**saturation vapour pressure** – air that attains its saturation vapour pressure has an equal number of water molecules evaporating from the water below into the air as the number of water molecules condensing from the air back into the water

**specific heat capacity** – the amount of energy needed to change the temperature of 1 kg of a substance by 1 °C

**specific latent heat of fusion** – the quantity of heat required to change 1 kg of a substance from the solid state to the liquid state

**specific latent heat of vaporisation** – the quantity of heat required to change 1 kg of a substance from the liquid state to the gaseous state

**sublimation** – the transition of a substance directly from the solid to the gas phase without passing through the intermediate liquid phase

**water vapour** – the gaseous phase of water

## Practice test: Answers

- 1.1 C  
 1.2 C  
 1.3 C  
 1.4 A  
 1.5 D  
 1.6 C  
 1.7 B  
 1.8 D  
 1.9 B  
 1.10 D  $(10 \times 2 = 20)$

2. Since the density of water is  
 $\rho = 1 \text{ g/cm}^3$ ,  $m = \rho V = 400 \text{ g} = 0.4 \text{ kg}$   
 $Q = mc\Delta T = 0.4 \text{ kg} \times 4200 \frac{\text{J}}{\text{kg}\cdot^\circ\text{C}}$   
 $(80^\circ\text{C} - 25^\circ\text{C}) = 9.24 \times 10^4 \text{ J}$  (3)

3. Amount of heat required to melt ice  
 and raise its temperature to  $10^\circ\text{C}$  is  
 $Q = mL_f + mc\Delta T$

$$= 0.1 \text{ kg} \times 334 \times 10^3 \frac{\text{J}}{\text{kg}} + 0.1 \text{ kg} \times$$

$$4200 \text{ J/kg}\cdot^\circ\text{C} \times (10^\circ\text{C} - 0^\circ\text{C})$$

$$= 3.34 \times 10^4 \text{ J} + 4.2 \times 10^3 \text{ J}$$

$$= 3.76 \times 10^4 \text{ J}$$

From  $P = \frac{W}{t}$  we have

$$t = \frac{W}{P} = \frac{Q}{P} = \frac{3.76 \times 10^4 \text{ J}}{140 \text{ W}} = 268.57 \text{ s}$$

$$= 4.48 \text{ min}$$
 (5)

4. a) This is to balance the heat lost  
 to the surroundings when the  
 system is above room  
 temperature by the heat taken  
 in from the surroundings when  
 the system is below room  
 temperature. (2)

b) From the conservation of  
 energy we have  
 $m_s c_s (T_f - T_{si}) + m_w c_w (T_f - T_{wi}) +$   
 $m_c c_c (T_f - T_{ci}) = 0$   
 where the subscript  $s$  is for the  
 copper block,  $w$  is for water and  $c$   
 is for the copper calorimeter.

Substituting the given values,  
 we have  $(0.1408 - 0.0925)\text{kg} \times$   
 $390 \text{ J/kg}\cdot^\circ\text{C} \times (23.2 - 93.3)^\circ\text{C}$   
 $+ (0.0925 - 0.0536)\text{kg} \times c_w$   
 $\times (23.2 - 15.9)^\circ\text{C} + (0.0536 \text{ kg}$   
 $\times 390 \text{ J/kg}\cdot^\circ\text{C} \times (23.2 - 15.9)^\circ\text{C}$   
 $= 0$   
 $\Rightarrow -1320.47 \text{ J} + 0.284c_w$   
 $+ 152.599 \text{ J}$   
 $= 0$   
 $\Rightarrow c_w = 4112 \text{ J/kg}\cdot^\circ\text{C}$  (6)

c) Yes, because a larger mass of  
 copper would result in a larger  
 change in temperature of the  
 mixture and a greater accuracy in  
 readings. (2)

5. a) In our calculations we only use the  
 mass of the dry steam and not the  
 mass of any accompanying water. (1)

b) From the conservation of energy  
 we have  $m_s L_v + m_s c_s (T_f - T_{si}) +$   
 $m_w c_w (T_f - T_{wi}) + m_c c_c (T_f - T_{ci}) = 0$   
 where the subscript  $s$  is for the  
 steam,  $w$  is for water and  $c$  is for  
 the copper calorimeter. Substituting  
 the given values, we have

$$- (0.0923 - 0.0912)\text{kg} \times L_v +$$

$$(0.0923 - 0.0912)\text{kg} \times 4200 \frac{\text{J}}{\text{kg}\cdot^\circ\text{C}} \times$$

$$(25 - 100)^\circ\text{C} + (0.0912 - 0.0505)\text{kg}$$

$$\times 4200 \frac{\text{J}}{\text{kg}\cdot^\circ\text{C}} \times (25 - 10^\circ\text{C}) +$$

$$(0.0505 \text{ kg} \times 390 \frac{\text{J}}{\text{kg}\cdot^\circ\text{C}} \times$$

$$(25 - 10)^\circ\text{C} = 0$$

$$\Rightarrow -1.1 \times 10^{-3} L_v - 346.5 \text{ J} +$$

$$2564.1 \text{ J} + 295.4 \text{ J} = 0$$

$$L_v = 2.28 \times 10^6 \frac{\text{J}}{\text{kg}}$$
 (6)

6. From the conservation of energy we  
 have  $m_s L_v + m_b c_b (T_f - T_{bi}) = 0$  where  
 the subscript  $s$  is for the sweat,  $b$  is for

the human body. Substituting the given values, we have

$$-m_s \times 2.42 \times 10^6 \frac{\text{J}}{\text{kg}} + 70 \text{ kg} \times$$

$$4200 \frac{\text{J}}{\text{kg} \cdot ^\circ\text{C}} \times 1^\circ\text{C} = 0$$

$$m_s = 0.12 \text{ kg} \quad (5)$$

7. a) Increase the external pressure and add an impurity such as a salt.

b) Increase the external pressure and add an impurity such as a salt. (4)

8. a)  $Q = W = Pt = 80$

$$100 \times 100 \text{ W}$$

$$\times 1 \text{ s} = 80 \text{ J/s} \quad (2)$$

b) The amount of heat required is given by  $Q + m_w c_w (T_f - T_{wi}) + m_w L_f + m_{ice} c_{ice} (T_f - T_{ice}) = 0$  where the subscript w is for the water.

$$Q + 0.02 \text{ kg} \times 4200 \frac{\text{J}}{\text{kg} \cdot ^\circ\text{C}} \times$$

$$(0 - 20)^\circ\text{C} - 0.02 \text{ kg} \times 3.34$$

$$\times 10^5 \frac{\text{J}}{\text{kg}}$$

$$+ 0.02 \text{ kg} \times 2100 \frac{\text{J}}{\text{kg} \cdot ^\circ\text{C}}$$

$$\times (-10 - 0)^\circ\text{C}$$

$$= 0$$

$$\Rightarrow Q = 8780 \text{ J} \quad (5)$$

c) From  $P = \frac{w}{t}$  we have

$$t = \frac{w}{P} = \frac{Q}{P} = \frac{8780 \text{ J}}{80 \text{ W}} = 109.75 \text{ s}$$

$$= 1.83 \text{ min} \quad (2)$$

9. a) The liquid HFC enters the evaporator inside the refrigerator. Once inside the evaporator, the HFC absorbs heat from the air inside the freezer, and evaporates partially. This evaporation cools the air in the freezer. (2)

b) The liquid and vapour mixture of the HFC is compressed by the motor before it enters the condenser. This compression results in the HFC being hotter than the air surrounding the condenser coils. The exchange of heat with the surroundings makes the temperature of the room to rise. (2)

10. From RH

$$= \frac{\text{actual water vapour pressure}}{\text{saturation vapour pressure}} \times 100\%$$

we have actual water vapour pressure

$$= \frac{\text{RH} \times \text{actual water vapour pressure}}{100\%}$$

$$= \frac{36\% \times 6.63 \text{ kPa}}{100\%} = 2.39 \text{ kPa} \quad (2)$$

11. a) Heat given off by steam is found from  $Q_s + m_s L_v + m_s c_w (T_f - T_i) = 0$  where the subscript w is for the water and s is for steam.

$$\Rightarrow Q_s - 0.01 \text{ kg} \times 2.42 \times 10^6 \frac{\text{J}}{\text{kg}} +$$

$$0.01 \text{ kg} \times 4200 \frac{\text{J}}{\text{kg} \cdot ^\circ\text{C}} \times$$

$$(34 - 100)^\circ\text{C}$$

$$= 0$$

$$\Rightarrow Q_s = 26972 \text{ J}$$

b) Heat given off by the boiling water is found from  $Q_w + m_s c_w (T_f - T_i) = 0$  where the subscript w is for the boiling water.

$$\Rightarrow Q_w + 0.01 \text{ kg} \times 4200 \frac{\text{J}}{\text{kg} \cdot ^\circ\text{C}}$$

$$\times (34 - 100)^\circ\text{C} = 0$$

$$\Rightarrow Q_w = 2722 \text{ J}$$

The heat given by the steam is 24250 J more than that given off by the boiling water. (4)

**Total mark: 73**

## TOPIC 4: Gas laws

### Performance objectives

- 4.1 identify and use instruments for measuring pressure
- 4.2 explain, using the ideas of the kinetic theory of gases:
  - **the** variation of pressure with volume of a gas when the temperature is kept constant (Boyle's law)
  - **the** variation of volume with temperature of a gas when the pressure is kept constant (Charles' law)
- 4.3 deduce the general gas law from a given mass of gas which obeys Charles' law
- 4.4 solve simple problems involving the gas laws

## Introduction

The students have already been introduced to some of the gas laws in Topic 3(A) of this theme on conservation principles. This topic extends the discussion on the gas laws and their applications to real life. A discussion on gas measuring instruments and the different units used to measure gas pressure also play an important feature of this topic. The various gas laws need to be explained on both the macro level (measurements of pressure, volume and temperature) and on the micro level (using the kinetic molecular theory).

The syllabus remains silent on the use of the equation  $PV = nRT$ , and therefore this form of the ideal gas law is not included in the text.

### Activity 2.14: Make a manometer

INDIVIDUAL OR PAIRS (SB p. 126)

#### Resources

100 cm × 20 cm × 1.5 cm timber, about 2 m of vinyl rubber tubing (clear plastic tubing), cable clips, water coloured with food colouring, metre rule, gas syringe, double-sided tape and a retort stand

#### Guidelines

If you have enough U-shaped glass tubing, you could use them instead of the vinyl tubing. Alternatively, you can use two straight glass tubes and join them with a piece of rubber tubing to form the 'U' part of the manometer. You could use a bicycle pump

instead of the syringe – even an inflated balloon will serve to change the manometer levels.

### Activity 2.15: Make a simple barometer

INDIVIDUAL OR PAIRS (SB p. 128)

#### Resources

An empty two-litre plastic bottle, 40 cm of clear plastic tubing, 30 cm ruler, water, food colouring, felt pen, adhesive tape and sticky putty

#### Guidelines

The following link shows another method of how to make a simple barometer: <https://www.youtube.com/watch?v=ah8F-xmvB2k>.

The following link is a video about the history of the barometer: <https://www.youtube.com/watch?v=EkDhlzA-lwI>.

### Activity 2.16: Determine the relationship between pressure and volume

INDIVIDUAL OR GROUPS (SB p. 129)

#### Resources

Boyle's law apparatus, bicycle pump and graph paper

#### Guidelines

Alternative apparatus to investigate Boyle's law are shown on the next page.

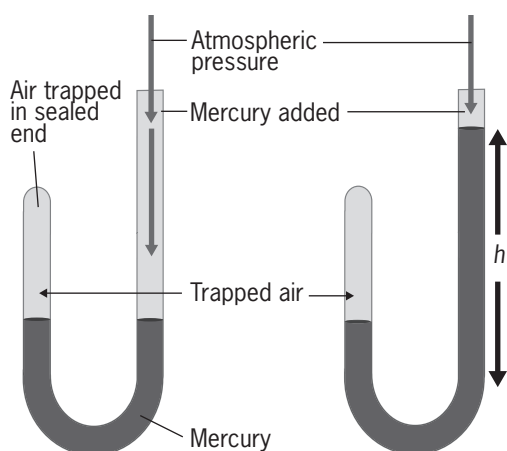
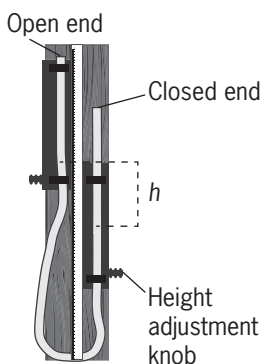

The following link discusses the experiment in the text: <https://www.youtube.com/watch?v=OKTGTIZfM1o>.

The following link shows a novel way of conducting the investigation: <https://www.youtube.com/watch?v=LOCqHxTVFvY>.

### Answers

- We need to let the temperature of the gas come down to the temperature of the room, so that the temperature is kept constant.
- $pV = \text{constant}$  pressure and volume are inversely proportional to each other.
- Temperature and mass of the gas.

### Activity 2.17: Determine the relationship between volume and absolute temperature

INDIVIDUAL OR GROUPS (SB p. 130)

### Resources

A tall beaker, capillary tube sealed at one end, 30 cm ruler, thermometer, rubber band,

metal stirrer, concentrated sulphuric acid, ice cubes, water, wire gauze, tripod stand, Bunsen burner, tripod stand, graph pages and syringe

### Guidelines

The following websites show alternative methods of doing Charles' law: [https://www.youtube.com/watch?v=nu\\_bBQYGK84](https://www.youtube.com/watch?v=nu_bBQYGK84)  
<https://www.youtube.com/watch?v=wkWo-8tY8cY>.

The following link shows a more complicated method: [https://www.youtube.com/watch?v=5M8GR6\\_zlps](https://www.youtube.com/watch?v=5M8GR6_zlps).

### Answers

- The capillary tube was open to the atmosphere, and hence the pressure of the gas was always equal to atmospheric pressure.

### How are you doing?

(SB p. 137)

Take this opportunity to ask students if there is anything that they do not understand. You can check their understanding by asking them some questions about the information covered in the unit. Explain anything that students do not understand.

### Key words

**aneroid barometer** – a device for measuring atmospheric pressure

**barometer** – any instrument that measures atmospheric pressure

**Bourdon gauge** – the instrument most widely used in industry to measure pressure

**Boyle's law** – states that the volume of a fixed mass of mass is inversely proportional to its pressure when the temperature of the gas is constant

**Charles' law** – states that the volume of a gas is directly proportional to its absolute temperature

**gauge pressure** – the absolute pressure minus the atmospheric pressure

**general gas law** – see ideal gas law



9. a) Since the temperature of the gas is constant, we can use Boyle's law with  $V_1 = 30 \ell$ ,  $p_2 = 1 \text{ atm}$ ,  $p_1 = 20 \text{ atm}$ , to determine the volume  $V_1$  of the escaping gas.

$$V_1 = \frac{p_2 V_2}{p_1} = \frac{1 \text{ atm} \times 30 \ell}{20 \text{ atm}} = 1.5 \ell \quad (3)$$

- b) The volume of the gas remaining in the cylinders is  $V_3 = 15 \ell$  with unknown pressure  $p_3$ . We use  $V_1 = 1.5 \ell$ ,  $p_1 = 20 \text{ atm}$  and Boyle's law to calculate  $p_3$ .

$$p_3 = \frac{p_1 V_1}{V_3} = \frac{20 \text{ atm} \times 1.5 \ell}{15 \ell} = 2 \text{ atm}. \quad (2)$$

10. a) In Figure A, the pressure of the gas is given by

$$\begin{aligned} p_1 &= p_{\text{atm}} + 10 \text{ cm Hg} \\ &= 76 \text{ cm Hg} + 10 \text{ cm Hg} \\ &= 86 \text{ cm Hg} \end{aligned}$$

In Figure B, the pressure of the gas is given by

$$\begin{aligned} p_2 &= p_{\text{atm}} - 10 \text{ cm Hg} \\ &= 76 \text{ cm Hg} - 10 \text{ cm Hg} \\ &= 66 \text{ cm Hg} \end{aligned}$$

The same mass of gas is trapped in both situations (Figures A and B) and at the same temperature. We can therefore use Boyle's law to find the length in Figure B:

$$\begin{aligned} p_1 V_1 &= p_2 V_2 \Rightarrow p_1 L_1 A = p_2 L_2 A \\ L_2 &= \frac{p_1 L_1}{p_2} = \frac{86 \text{ cm Hg} \times 30 \text{ cm}}{66 \text{ cm Hg}} \\ &= 39.1 \text{ cm} \end{aligned} \quad (4)$$

- b) The pressure of the gas in Figure C is same as that of the atmosphere, hence

$$p_3 = p_{\text{atm}} = 76 \text{ cm Hg}.$$

Again using Boyle's law, we have

$$\begin{aligned} p_1 V_1 &= p_3 V_3 \Rightarrow p_1 L_1 A = p_3 L_3 A \\ L_3 &= \frac{p_1 L_1}{p_3} = \frac{80 \text{ cm Hg} \times 30 \text{ cm}}{76 \text{ cm Hg}} \\ &= 33.9 \text{ cm} \end{aligned} \quad (3)$$

**Total mark: 58**

**TOPIC 1: Production and propagation of waves****Performance objectives**

- 1.1 generate mechanical waves
- 1.2 state the important characteristics of waves
- 1.3 produce circular and plane waves using a ripple tank
- 1.4 generate and demonstrate longitudinal and transverse waves using suitable materials
- 1.5 identify the crest, trough, amplitude, wavelength and points in phase on a given sine wave form
- 1.6 derive and use the relationship between wave velocity, frequency and wavelength
- 1.7 identify light as electromagnetic waves

**Introduction**

This topic is an introduction to mechanical waves. Unlike electromagnetic waves, mechanical waves need a medium for transmission. Stress the fact that waves transfer energy and not matter from one point to another. The particles in a mechanical wave do undergo motion, but this only occurs about the particles' equilibrium position, without the particles along the direction of the wave. The topic introduces the basic terms used in wave terminology. The basic equipment needed for this topic are a rope, 'slinky' and a ripple tank. If the school does not have a ripple tank, you could use a clear plastic rectangular dish placed on an overhead projector. Waves can be generated on the surface of water poured into the dish by using a ruler (plane waves) or with the finger (circular waves).

The following link is a series of lessons on waves and includes some ripple tank demonstrations: <https://www.youtube.com/watch?v=y53z2zVipAs>.

**Activity 3.1: Generate mechanical waves and find the speed of a wave**

GROUPS (SB p. 141)

**Resources**

A long rope, ribbon, stopwatch, metre rule and 'slinky'

**Guidelines**

A pulse is created by a single disturbance, while a wave is created by a succession of disturbances. In both cases energy is transported from one point to another. An important feature of this activity is to note that the ribbon does not move with the wave, but oscillates to and fro about its equilibrium position. The tension in the rope needs to be the correct amount for a pulse to be observed moving along the rope. This activity is also used to measure the speed of the wave.

**Answers**

5. The ribbon does not move with the pulse. The ribbon got its energy from the pulse. Yes.
6. The ribbon does not move with the wave. Yes, the waves carry energy, as it is evident that this energy was used to make the ribbon move up and down. The disturbance (hand) moves vertically, while the wave moves horizontally, with the two motions being perpendicular to each other.

### Activity 3.2: Generate water waves using a ripple tank

GROUPS (SB p. 143)

#### Resources

A ripple tank with accessories, polystyrene ball, ruler, long rope, ribbon, stopwatch, metre rule and 'slinky'

#### Guidelines

Make sure that the plane wave dipper is horizontal and touches the water surface evenly. Adjust the rheostat so that you get a good set of plane waves formed on the surface of the water. The students should place a blank sheet of paper underneath the ripple tank and trace out the image of the plane waves on the sheet.

#### Answers

8. The distance between two successive crests is equal to the distance between two successive troughs.
9. The polystyrene ball moves up and down because of the energy transmitted by the waves.
12. When the frequency was changed, the distance between two successive crests (troughs) also changed, but the speed of the waves did not change.

#### How are you doing? (SB p. 148)

Take this opportunity to ask students if there is anything that they do not understand. You can check their understanding by asking them some questions about the information covered in the unit. Explain anything that students do not understand.

#### Key words

**amplitude** – the maximum displacement of the wave from its equilibrium position (the time axis)

**circular waves** – move outwards from the source in all directions

**crest** – the peak of a wave

**direction of oscillation** – the direction of movement back and forth at a regular speed

**direction of propagation** – the direction of energy flow at any given point

**electromagnetic wave** – waves that contain an electric field and a magnetic field and carry energy; they travel at the speed of light

**frequency** – the number of times that something (such as a sound wave or radio wave) is repeated in a period of time (such as a second)

**longitudinal wave** – a wave vibrating in the direction of propagation

**mechanical wave** – a wave that is an oscillation of matter, and therefore transfers energy through a medium

**phase** – any stage in a series of events or in a process of development

**plane wave** – a constant-frequency wave whose wave fronts (surfaces of constant phase) are infinite parallel planes of constant peak-to-peak amplitude normal to the phase velocity vector

**ripple tank** – a shallow glass tank of water used in schools and colleges to demonstrate the basic properties of waves

**transverse wave** – a moving wave that consists of oscillations occurring perpendicular (or right-angled) to the direction of energy transfer

**trough** – in a wave, the points of maximum displacement of the oscillating water particles below the equilibrium position

**wavelength** – the distance between any two successive crests (or troughs)

## Practice test: Answers

- 1.1 C (5 × 2 = 10)  
 1.2 A  
 1.3 C  
 1.4 D  
 1.5 D  
 2. A pulse is caused by a single disturbance while a wave is caused by a number of repetitive disturbances. (2)

3.

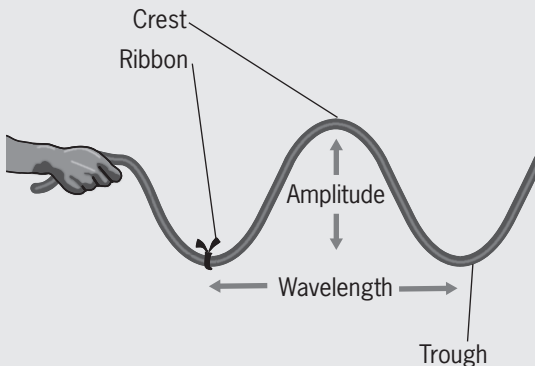

4. a)  $T = \frac{3 \text{ s}}{50} = 0.6 \text{ s}$  (4)  
 b)  $v = \frac{\lambda}{t} = \frac{350 \text{ cm}}{15 \text{ s}} = 23.3 \text{ cm/s}$  (2)  
 5. a)  $A = 0.4 \text{ cm}$  (2)  
 b)  $f = \frac{1}{T} = \frac{1}{0.4 \text{ s}} = 2.5 \text{ Hz}$  (1)  
 c)  $\lambda = \frac{v}{f} = \frac{0.1 \text{ m/s}}{2.5 \text{ Hz}} = 0.04 \text{ m}$  (3)

6. The frequency of the waves is given by:

$$f = \frac{v}{\lambda} = \frac{20 \text{ cm/s}}{3 \text{ cm}} = 6.67 \text{ Hz}$$

The frequency in the second part of the ripple tank will be the same as in the first, which is  $f = 6.67 \text{ Hz}$ . The wavelength in the second part will be:

$$\lambda' = \frac{v'}{f} = \frac{15 \text{ cm/s}}{6.67 \text{ Hz}} = 2.25 \text{ cm} \quad (3)$$

7. Water waves need a medium for propagation while light waves do not. Water waves travel much slower than light waves. (2)

8.  $f = \frac{v}{\lambda} = \frac{3 \times 10^8 \text{ m/s}}{700 \times 10^{-9} \text{ cm}} = 4.29 \times 10^{14} \text{ Hz}$  (2)

9.  $f = \frac{v}{\lambda} = \frac{332 \text{ m/s}}{1.1 \times 10^{-2} \text{ m}} = 30\,181 \text{ Hz}$   
 Since the maximum frequency for hearing is 20 000 Hz, this sound will not be heard. (3)

10. The period of the tsunami waves is  $T = 1 \text{ h}$ , and the wavelength is  $\lambda = 800 \text{ km}$ . The speed of the waves is given by:

$$v = f\lambda = \frac{1}{T}\lambda = \frac{1}{1 \text{ h}} \times 800 \text{ km} = 800 \text{ km/h}$$

The speed of the tsunami waves was about 2.7 times greater than that of a jet liner. (3)

**Total mark: 39**

## TOPIC 2: Types of waves

### Performance objectives

- 2.1 classify waves into longitudinal and transverse waves by using:
- **mode** of vibration
  - **direction** of propagation
- 2.2 write down and explain the terms in the wave equation

## Introduction

This topic is mainly about differentiating between transverse waves and longitudinal waves. Another important concept which is introduced is the wave function. Some of the concepts such as angular frequency may prove to be too abstract for the students, such as angular frequency. To avoid this, try to relate this frequency to the angular velocity of rotatory motion.

The following link shows a good demonstration of transverse and longitudinal waves and shows how they are obtained using different approaches. It also touches on sound waves: <https://www.youtube.com/watch?v=jAXx0018QCc>.

### Activity 3.3: Differentiate between longitudinal and transverse waves

GROUPS (SB p. 151)

#### Answers

9. The direction of oscillation is parallel to the direction of propagation.

### How are you doing?

(SB p. 154)

Take this opportunity to ask students if there is anything that they do not understand. You can check their understanding by asking them some questions about the information covered in the unit. Explain anything that students do not understand.

### Key words

**compression** – region of high air pressure  
**rarefaction** – (in a sound wave) an area of low density of molecules  
**wave function** – variable quantity that mathematically describes the wave characteristics of a particle

## Practice test: Answers

- 1.1 C  
 1.2 D  
 1.3 B  
 1.4 A  
 1.5 C
2. In a transverse wave the direction of oscillation is perpendicular to the direction of propagation, while in a longitudinal wave the direction of oscillation is parallel to the direction of propagation. (2)
3. Longitudinal waves are made of compression and rarefactions of particles, and a vacuum has no such particles. (2)
4. a)  $A = 0.11 \text{ m}$  (1)  
 b)  $\lambda = \frac{2\pi}{8.5} = 0.74 \text{ m}$  (2)  
 c)  $\frac{2\pi}{T} = \omega = 20 \Rightarrow T = 0.31 \text{ s}$  (2)  
 d)  $v = f\lambda = \frac{\lambda}{T} = \frac{0.74 \text{ m}}{0.31 \text{ s}} = 2.36 \text{ m/s}$  (2)
5. a)  $\lambda = \frac{2\pi}{0.38} = 16.53 \text{ m}$ , which is the distance between two crests (2)  
 b) The frequency of the waves is given by:  
 $2\pi f = \omega = 4.70 \Rightarrow f = 0.748 \text{ Hz}$

The number of waves

approaching her in 20 s is:

$$n = 0.748 \text{ Hz} \times 20 \text{ s} = 14.96 \quad (3)$$

c)  $v = f\lambda = 0.748 \text{ Hz} \times 16.53 \text{ m}$   
 $= 12.36 \text{ m/s} \quad (2)$

6. a) Transverse (1)

b)  $T = 2 \text{ s} \Rightarrow \omega = 2\pi T = 2\pi \times 2 \text{ s}$   
 $= 12.57 \text{ s}^{-1}$

$$\frac{2\pi}{\lambda} = \frac{2\pi}{0.45 \text{ m}} = 13.96 \text{ m}^{-1}$$

The wave function is:

$$Y = A \sin\left(\frac{2\pi}{\lambda}x - \omega t\right)$$

$$= 0.12 \sin(13.96x - 12.57t) \quad (4)$$

c) The graph of the wave is shown below. (3)

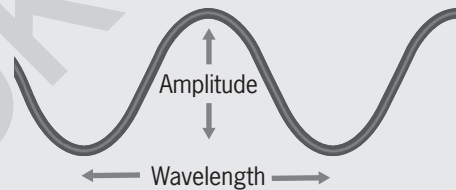

**Total mark: 36**

## TOPIC 3: Properties of waves

### Performance objectives

- 3.1 produce plane and circular waves using a ripple tank
- 3.2 demonstrate the reflection of sound
- 3.3 demonstrate stationary waves
- 3.4 demonstrate the reflection of heat radiation
- 3.5 demonstrate the refraction of water waves and sound

## Introduction

In this topic we discuss some of the important properties of waves. The students will also encounter reflection and refraction in the next topic on light. The ripple tank is a useful tool to show reflection and refraction of water waves. The topic also introduces students to the principle of superposition and the formation of standing or stationary waves.

### Activity 3.4: Investigate the reflection of water waves

GROUPS (SB p. 157)

#### Resources

A ripple tank with accessories

#### Guidelines

The students should place a blank sheet of paper underneath the ripple tank and trace out the image of the incident wave, barrier and reflected plane waves on the sheet. The geometrical constructions need to be as accurate as possible to get the desired results.

The following web site shows the ripple tank reflection and refraction experiments: <https://www.youtube.com/watch?v=8LrrWvfyqLo>.

The following site is a simulated package of the ripple tank experiments: <https://www.youtube.com/watch?v=R5EdLv3NS7Y>.

### Activity 3.5: Investigate the reflection of sound waves

GROUPS (SB p. 159)

#### Resources

Hard board or a stiff cardboard, two cardboard tubes, rectangular cardboard, a protractor, a clock or buzzer, and a retort stand

#### Guidelines

This is not a very accurate experiment to conduct.

The following site gives an alternate method of conducting the experiment:

<https://www.youtube.com/watch?v=5bT0BQx9UI8>.

### Activity 3.6: Investigate the reflection of heat waves

GROUPS (SB p. 160)

#### Resources

A rectangular piece of black cardboard, a protractor, burning candle, thermometer and a retort stand

#### Guidelines

Demonstrate the procedure as set out in the Student's Book. Monitor the groups as they do the activity and assist where necessary.

### Activity 3.7: Investigate the refraction of water waves

INDIVIDUAL (SB p. 163)

#### Resources

A ripple tank with accessories

#### Guidelines

The following web site shows the ripple tank reflection and refraction experiments: <https://www.youtube.com/watch?v=8LrrWvfyqLo>.

The following site is a simulated package of the ripple tank experiments: <https://www.youtube.com/watch?v=R5EdLv3NS7Y>.

**How are you doing?** (SB p. 165)

Take this opportunity to ask students if there is anything that they do not understand. You can check their understanding by asking them some questions about the information covered in the unit. Explain anything that students do not understand.

**Key words**

- angle of incidence** – the angle made between the incident ray and the normal
- angle of refraction** – The angle made by the direction of the refracted wave and the normal
- angle of reflection** – the angle made between the reflected ray and the normal
- antinode** – the points of maximum displacement and maximum energy
- node** – a point along a standing wave where the wave has minimum amplitude
- principle of superposition** – if two or more travelling waves are moving through a point in a medium, the resultant amplitude is the algebraic sum of the amplitudes of the individual waves' reflection
- refraction** – change in direction of propagation of any wave as a result of its travelling at different speeds at different points along the wave front
- standing wave** – also called stationary wave; a combination of two waves moving in opposite directions, each having the same amplitude and frequency
- travelling wave** – a wave in which the medium moves in the direction of propagation

# Practice test: Answers

- 1.1 B  
 1.2 A  
 1.3 B  
 1.4 D  
 1.5 C (5 × 2 = 10)

2. Both incident and reflected waves travel in the same medium, while the refracted wave travels in a different medium to that of incident wave. The reflected wave travels with the same speed and wavelength as the incident wave, while the refracted wave travels at a different speed and with a different wavelength compared to the incident wave. (2)

3. The two laws are:

- The incident wave, reflected wave and the normal to the surface all lie in the same plane.
- The angle of incidence is equal to the angle of reflection. (2)

4. a)

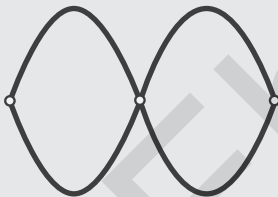

b)



5. a) After 3 s, each of the waves would have moved 6 cm and the trough of A would overlap the crest of B. The resultant wave would appear as follows:

(2)

(2)

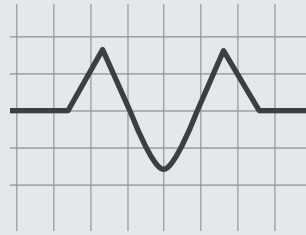

(4)

b) The principle of superposition states that if two or more travelling waves are moving through a point in a medium, the resultant amplitude is the algebraic sum of the amplitudes of the individual waves. (2)

6. The diagram should appear as follows:

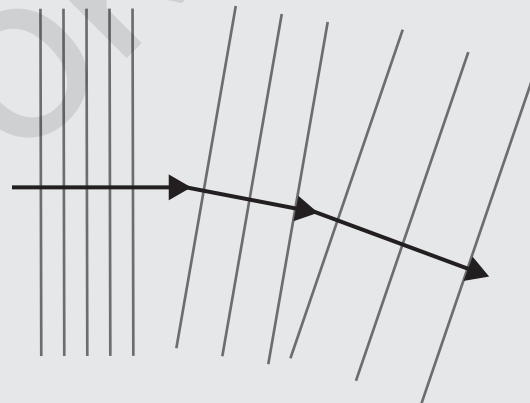

Note the change in wavelengths and directions for each of the three regions. (4)

7. a) Medium A. (1)

b) From the second law of refraction, we have:

$$\frac{\sin i}{\sin r} = \frac{v_i}{v_r}$$

and

$$\sin r = v_r \frac{\sin i}{v_i} = 7 \text{ cm/s} \frac{\sin 54^\circ}{16 \text{ cm/s}} = 0.35$$

with  $r = 20.7^\circ$ . (4)

**Total mark: 33**

## TOPIC 4: Light waves

### Performance objectives

- 4.1 list some light sources you come across in everyday life
- 4.2 determine the angle of reflection for a given angle of incidence
- 4.3 draw ray diagrams to show the formation of images by plane and curved mirrors
- 4.4 explain some practical applications of plane and curved mirrors
- 4.5 explain how the direction of light changes as it travels from one medium into another
- 4.6 measure angles of incidence and refraction and hence deduce a value for the refractive index of a given material
- 4.7 explain the meaning of critical angle and total internal reflection, stating the conditions under which they occur
- 4.8 establish the relationship between critical angle and refractive index, and apply it to the solution of simple problems
- 4.9 trace light rays through a triangular prism and obtain graphically the value of the angle of minimum deviation
- 4.10 obtain the spectrum of white light
- 4.11 describe the spectrum of solar energy received by Earth
- 4.12 obtain images due to light rays through converging and diverging lenses using: ray tracks; ray tracing method
- 4.13 use the lens formula to solve numerical problems on lenses

## Introduction

We have found light a satisfying subject to teach, perhaps because so much of what students are required to learn, falls very easily into their experience of light. The subject lends itself to various simple demonstrations and experiments, and gives a means of access to important optical instruments.

### Activity 3.8: Investigate the first law of reflection

PAIRS OR SMALL GROUPS (SB p. 172)

#### Resources

A small plane mirror, a wooden board, paper, pencil, protractor and some 'optical pins'

#### Guidelines

Optical pins are large pins about 4 to 5 cm long. You can use ordinary pins or 5 cm long nails, if necessary.

Go through the procedure laid down with the students. Monitor the groups during the activity and give support where necessary.

### Activity 3.9: Investigate refraction

PAIRS OR SMALL GROUPS (SB p. 174)

#### Resources

Each group will need at least 1 square metre of space on the laboratory bench, plus a piece of softboard of about  $\frac{1}{2}$  metre square, A3 sheet of white paper, four optical pins, protractor, pencil and ruler and a glass block, which is difficult to improvise. Glass blocks are obtainable from various scientific supply houses, and your school should have at least ten of them for laboratory demonstrations.

#### Guidelines

If it is not convenient to offer the activity in groups, you might do it as a demonstration, and bring four to five students at a time to the optical bench so that they can see how the data are obtained.

The paper is placed on the softboard and two pins are fixed into the board, about 10 cm apart and standing vertically. The block of glass is placed on the paper, in such a way that a pencil line joining the two pins, and extended, meets the longer side of the block at an angle of about 45 degrees. The two pins are now viewed through the glass, and two

more pins are fixed into the board such that they are in a straight line with the first two pins, as seen through the glass. The glass is removed after its edges have been drawn on the paper. Also remove the four pins.

By drawing lines from the pin holes to meet the opposite sides of the block, as represented by the pencil lines, and joining the lines across the 'gap' represented by the glass block, a light path is traced out. This path shows the refraction of the light as it enters and as it leaves the glass.

Construct a normal (i.e. a perpendicular) at the points where the light paths (pencil lines) meet the edges of the block. Now you can label the angle of incidence and the angle of refraction. These are measured with a protractor, and  $\sin i/\sin r$  calculated. This is the refractive index for a light ray travelling from air into glass.

### Activity 3.10: Draw light rays

INDIVIDUAL (SB p. 175)

#### Guidelines

On the basis of what the students have learnt with the previous graphical construction, they draw some rays passing through a glass block in which the two sides are not parallel.

### Activity 3.11: Use a prism to produce a spectrum

PAIRS OR SMALL GROUPS (SB p. 176)

#### Resources

A prism

#### Guidelines

Students should work in pairs or small groups, but a demonstration is just as impressive, and should be done if only one prism is available. Show the students the prism, and point out to them that this is a 'dispersive prism', designed such that it will produce a spectrum if 'white' light passes through it. If your laboratory has the 'ordinary' sort of prism ( $90^\circ$ ,  $45^\circ$ ,  $45^\circ$ ) show this to the students so that they can see the difference in shape.

A spectrum is easily thrown onto a white surface with a dispersive prism. Tell the students that by including a set of lenses with

the prism it is possible to produce a very sharp separation of the colours. Ask students if they know the colours of the rainbow.

### Activity: 3.12: Use a lens to project an image on a wall

INDIVIDUAL (SB p. 178)

#### Guidelines

There will probably be some students in the class who wear spectacles, and these can be used (with the permission of the owners) to demonstrate 'real image' formation, by holding the lenses about a metre away from a white wall, and directing them at a brightly-lit scene. Explain to the students that only convex lenses will form a real image, and that convex lenses are used to correct long-sightedness. Students who are short-sighted will have concave lenses, which will not form a 'real image'.

#### How are you doing?

(SB p. 181)

Take this opportunity to ask students if there is anything that they do not understand. You can check their understanding by asking them some questions about the information covered in the unit. Explain anything that students do not understand.

#### Key words

**bioluminescence** – the production and emission of light by a living organism

**electroluminescence** – light production by LEDs

**ether ('aether')** – the rarefied element formerly believed to fill the upper regions of space

**incandescent** – emitting light as a result of being heated

**LED** – a light-emitting diode

**photoelectric effect** – the observation that many metals emit electrons when light shines upon them

## Practice test: Answers

1. 'Helios' is 'sun' in Greek. (2)
2. About 300 000 km per second. (2)
3. The main consequence is that light is 'bent' (refracted) when it passes from one medium into another in which its speed is different. (4)
4. 'Specular' means 'mirror-like'. (2)
5. The angle of incidence is equal to the angle of reflection, and the incident ray, the reflected ray and the normal all lie in the same plane. (4)
6. Spherical aberration. A parabolic surface does not have this type of aberration. (4)
7.  $\sin i$  divided by  $\sin r$ . (4)
8. The 'critical angle' is the angle of incidence for a ray travelling from an optically dense medium to an optically less dense one, for which the angle of refraction is  $90^\circ$ . (4)
9. The lens designed to correct long-sightedness (a convex lens) will produce a real image. (2)
10. A 'simple lens' is a single piece of (thin) glass or plastic. A 'compound lens' is made of two or more (sometimes as many as seven) simple lenses close together, or cemented together with a special transparent 'cement'. Compound lenses are preferred because a simple lens does not produce a good image. It suffers from various types of 'defect', called 'aberrations'. The 'elements' (components) of a compound lens are designed to correct each other's aberrations, thus a compound lens has fewer and smaller aberrations. (4)
11. About 4 million tonne every second. (2)

**Total mark: 36**

## TOPIC 5: Sound Waves

### Performance objectives

- 5.1 identify the vibrating sources when sound is produced
- 5.2 distinguish between:
  - **noise** and music
  - **intensity** and loudness
  - **pitch** and frequency applied to sound
- 5.3 explain forced vibration and explain how it is used to amplify a sound
- 5.4 use the relationship  $v = f\lambda$  in solving numerical problems
- 5.5 explain the formation of standing waves and produce these waves in stretched strings
- 5.6 use the resonance tube to determine the velocity of sound in air

## Introduction

Discuss a life without being able to hear or make sound. List the different sources of sound. The topic then focuses on the properties and characteristics of sound waves. If the school has an oscilloscope and signal generator, these tools will help to enhance your teaching of this topic.

The following video series gives an excellent visual account of the production and transmission of sound: <https://www.youtube.com/watch?v=nGKffdaI4Pg>.

The following link also provides some useful visuals on sound: <https://www.youtube.com/watch?v=GkNJvZINSEY>.

### Activity 3.13: Investigate the sources of sound

INDIVIDUAL (SB p. 183)

#### Resources

A tuning fork, plastic ruler, piece of very thin wire, nylon string (fishing line), empty coffee can and a balloon

#### Guidelines

Demonstrate how to set up the apparatus to be used in the activity and go through the laid down procedures and demonstrate the investigation.

Let the students do the investigation. Monitor their progress and give support where necessary.

### Activity 3.14: Investigate sound in a vacuum

GROUPS (SB p. 185)

#### Resources

A bell jar with a metal base, a source of sound like a mobile phone, a vacuum pump, petroleum jelly

#### Guidelines

This activity is a modern version of the familiar doorbell-in-a-bell-jar experiment, in that it uses a mobile or cell phone as the source of sound. If faint traces of the sound are heard as the bell jar is evacuated, they could result from the sound being transmitted from the bottom of the bell jar at the point where the mobile phone makes contact with the bell jar.

You can watch a similar experiment at <https://www.youtube.com/watch?v=JrU9LouWY18>.

### Activity 3.15: Investigate resonance

GROUPS (SB p. 189)

#### Resources

Three tuning forks on resonance boxes, two of them having the same frequency, and a sonometer

#### Guidelines

The link on the next page (series 33, 34 and 35) shows demonstrations of resonance by the legendary late Professor Julius Sumner-Miller:

<https://www.youtube.com/watch?v=C-Bn70PpbrM>.

The following link shows a glass tumbler being shattered by resonance: <https://www.youtube.com/watch?v=z6oqPB07X3o>.

### Answers

6. The third tuning fork does not resonate, because it does not have the same natural frequency as the first.

### Activity 3.16: Determine the speed of speed of sound in air

GROUPS (SB p. 193)

#### Resources

A tuning fork of frequency 512 Hz, resonance tube, metre stick and a thermometer

#### Guidelines

The following link will be useful to your teaching of this section on standing waves and tube resonance and determining the speed of sound using resonance: <https://www.youtube.com/watch?v=bHdHaYNX4Tk>.

An alternative apparatus which you can use for this activity is shown below.

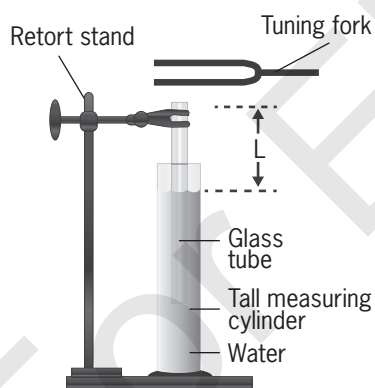

#### How are you doing? (SB p. 197)

Take this opportunity to ask students if there is anything that they do not understand. You can check their understanding by asking them some questions about the information covered in the unit. Explain anything that students do not understand.

### Key words

**bass** – low in pitch; of the lowest pitch or range

**compression (region of)** – (in a sound wave) an area of high density of molecules

**fundamental frequency** – the lowest frequency produced by the oscillation of the whole of an object, as distinct from the harmonics of higher frequency

**harmonics** – an integer (whole number) multiple of the fundamental frequency

**harmonic series** – the lowest possible frequency at which a string could vibrate to form a standing wave pattern is known as the fundamental frequency or the first harmonic; the second lowest frequency at which a string could vibrate is known as the second harmonic; the third lowest frequency is known as the third harmonic

**musical note** – the note of the guitar and piano are called musical notes

**noise** – combination of all the frequencies of sound with no particular pattern

**normal modes** – a normal mode of an oscillating system is a pattern of motion in which all parts of the system move sinusoidally with the same frequency and with a fixed phase relation

**overtone** – any frequency higher than the fundamental frequency of a sound

**pitch** – the quality of a sound governed by the rate of vibrations producing it; the degree of highness or lowness of a tone

**pressure amplitude** – directly related to the acoustic energy or intensity of a sound

**pure note** – the note of a tuning fork is called a pure note

**resonance** – when one object vibrating at the same natural frequency of a second object forces that second object into vibrational motion

**resonance box** – a resonance box uses resonance to amplify sound. The chamber has interior surfaces which reflect an acoustic wave

**sonometer** – an apparatus made of a hollow box having two holes; a string is attached to it by which the transverse vibrations of strings can be studied

**third harmonic** – see harmonic series

**timbre** – the character or quality of a musical sound or voice as distinct from its pitch and intensity

**treble** – in music, high pitched sounds

**tuning fork** – an acoustic resonator in the form of a two-pronged fork with the prongs (tines) formed from a U-shaped bar of elastic metal (usually steel)

## Practice test: Answers

- 1.1 C  
 1.2 D  
 1.3 B  
 1.4 A  
 1.5 B  
 1.6 A  
 1.7 B  
 1.8 D  
 1.9 D  
 1.10 B (10 × 2 = 20)

2. Pitch depends on frequency.  
 Loudness depends on amplitude.  
 Quality depends on overtones. (3)

3. Resonance occurs when one vibrating object forces a second object to vibrate if the natural frequency of vibration of the second object is the same as the frequency of the first. (2)

4. Time taken for sound to travel in air is:

$$t_{\text{air}} = \frac{s}{v_{\text{air}}} = \frac{200 \text{ m}}{330 \text{ m/s}} = 0.61 \text{ s}$$

Time taken for sound to travel in aluminium (Al) is:

$$t_{\text{Al}} = \frac{s}{v_{\text{Al}}} = \frac{200 \text{ m}}{6400 \text{ m/s}} = 0.03 \text{ s}$$

The difference in the two times is:  
 0.61 s – 0.03 s = 0.58 s. (4)

5. a) At resonance we have for the fundamental frequency:  
 $f = \frac{v}{4L} = \frac{343 \text{ m/s}}{4 \times 0.167 \text{ m}} = 513.5 \text{ Hz}$  (2)

b) Second resonance occurs at:  
 $f = \frac{3v}{4L}$ ,  
 from which we get:  
 $L = \frac{3v}{4f} = \frac{3 \times 343 \text{ m/s}}{4 \times 513.5 \text{ Hz}} = 0.50 \text{ m}$   
 = 50 cm (2)

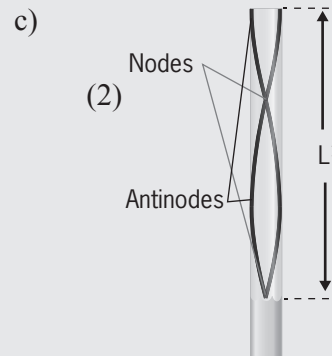

6. The length of the pipe can be found from:  
 $f = \frac{v}{2L} \Rightarrow L = \frac{v}{2f} = \frac{v}{2 \times 260} = \frac{v}{520}$   
 The fundamental frequency of the closed pipe is:  
 $f' = \frac{v}{4L} = \frac{v}{4 \times \frac{v}{520}} = 130 \text{ Hz}$  (3)

7. a) The wavelength of the sound waves is given by:

$$\lambda = \frac{v}{f} = \frac{340 \text{ m/s}}{1020 \text{ Hz}} = 0.33 \text{ m}$$

- b) There will be a node at the wall (closed end) and an antinode at the loudspeaker (open end). See diagram below. The distance between the four nodes is  $4 \times \frac{\lambda}{2} = 0.66 \text{ m}$ , and the distance between the last node and the loudspeaker is  $\frac{1}{2}\lambda = 0.083 \text{ m}$ . The distance between the loudspeaker and the wall is  $0.743 \text{ m}$ . (4)

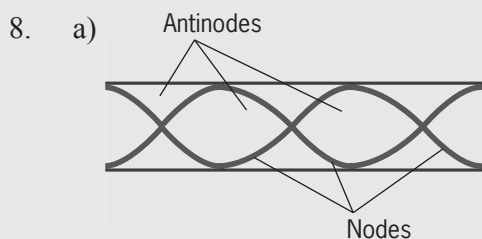

- b) From  $f_3 = \frac{3v}{2L}$ ,

we have

$$L = \frac{3v}{2f_3} = \frac{3 \times 340 \text{ m/s}}{2 \times 300 \text{ Hz}} = 1.7 \text{ m} \quad (2)$$

9.  $f_2 = 2f_1 = 2 \times 600 \text{ Hz} = 1200 \text{ Hz}$ . (2)



(2)

10. a)

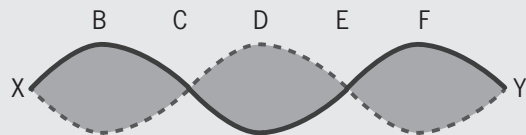

(2)

- b) The string is vibrating in its third harmonic, which is given by the frequency:

$$f_3 = 3f_1 = 3 \times 300 \text{ Hz} = 900 \text{ Hz} \quad (2)$$

The distance between E and Y is  $30 \text{ cm}$  (on the sonometer diagram) and this length is equal to  $\frac{\lambda}{2}$ . Thus the wavelength is  $60 \text{ cm} = 0.6 \text{ m}$ . (3)

- c) The frequency of the sound waves is the same as that of the vibrating string, which is  $900 \text{ Hz}$ .

The wavelength of the sound waves is given by:

$$\lambda = \frac{v}{f} = \frac{330 \text{ m/s}}{900 \text{ Hz}} = 0.37 \text{ m} \quad (2)$$

**Total mark: 58**

## TOPIC 6: The human eye

### Performance objectives

- 6.1 explain the role played by some parts of the eye in the formation of an image on the retina
- 6.2 compare and contrast the eye and the camera
- 6.3 state the main defects of the eye, and their causes
- 6.4 identify the type of lenses for correcting the various optical defects of the eye

## Introduction

In our own teaching of physics we have always welcomed the opportunity to discuss subjects that fall into ‘surrounding’ disciplines. The eye is a good example. Many students will presumably have learnt something about the eye in biology. ‘Visiting’ other subjects in a physics course helps students to see the relevance of physics to other aspects of science, and to broaden their understanding of those other aspects through the very powerful and general medium of physics.

### Activity 3.17: Find your blind spot

INDIVIDUAL (SB p.203)

#### Guidelines

Students use the diagram at the bottom of the page to find their blind spot.

### Activity 3.18: Experiments with vision

INDIVIDUAL (SB p. 205)

#### Guidelines

In this age group students should find that the near point is about 10 cm away, or even less. Tell students that the near point ‘recedes’ as they get older, due to changes in the elasticity of the lens. You might consider determining your own ‘near point’ and allowing the students to compare their values with yours.

The students will probably not need any help to grasp the point of the exercise. They should be told that seeing things with two eyes is a great help in judging the distances of objects. Indeed the method of parallax is important in astronomy, in which a given object is viewed against the background of the distant stars, from opposite sides of the Earth’s orbit.

### How are you doing?

(SB p. 208)

Take this opportunity to ask students if there is anything that they do not understand. You can check their understanding by asking them some questions about the information covered in the unit. Explain anything that students do not understand.

### Key words

**aperture** – a hole or an opening through which light travels

**aqueous** – water-like or watery

**astigmatism** – a condition in which the lens, or sometimes the surface of the cornea, is incorrectly shaped

**bifocal lens** – lens having one part that corrects for near vision and one for distant vision

**dioptré (=dioptr)** – the unit in which the ‘focusing power’ of a lens is measured

**hyperopia (=hypermetropia)** – long-sightedness

**macula lutea** – a small area of the retina, almost directly opposite the centre of the lens, where the photoreceptors are smaller and more tightly packed than elsewhere on the retina

**myopia** – short-sightedness

**presbyopia** – long-sightedness (also ‘old sight’)

**stereoscopic vision** – the perception of depth and 3-dimensional structure obtained on the basis of visual information deriving from two eyes by individuals with normally developed binocular vision

**vitreous** – glass-like

## Practice test: Answers

1. Photoreceptors are cells that are sensitive to light. They undergo electrical changes on their surfaces when light energy strikes them, and these electrical changes activate nerve cells which are in contact with the photoreceptor cells. The cells are found in the retina. (4)
2. Vitreous means 'glass-like'. (2)
3. 'Accommodation' is the process by which the eye focuses an image on the retina. Unlike the process in a camera, where the lens moves, accommodation involves a change in the shape of the lens of the eye, and thus a change in its focal length. (2)
4. A 'dark-adapted eye' is one that is maximally sensitive to light, because it has been in darkness for some time. During the process of adaptation, light-sensitive chemicals build up to a high concentration in the photoreceptors, making them maximally sensitive to the light that falls on them. (4)
5. 'Cataract' is a condition of the lens of the eye, in which it becomes cloudy. This cloudiness reduces the ability of the lens to produce a bright, sharp image on the retina. Poor vision results. Cataract can become so severe that the person may become blind in one or both eyes. (4)

**Total mark: 16**

## TOPIC 7: Application of sound waves

### Performance objectives

- 7.1 classify musical instruments into:
- **wind** instruments
  - **stringed** instruments
  - **percussion** instruments
- 7.2 explain the physical principles involved in the use of wind, string and percussion instruments
- 7.3 use the reflection of sound to explain echoes
- 7.4 give an application of echoes
- 7.5 explain the functioning of hearing aids

## Introduction

This topic focuses on the application of standing waves in strings and pipes to the making of musical instruments. The concepts of echoes and their uses are also discussed in this topic.

### How are you doing? (SB p. 220)

Take this opportunity to ask students if there is anything that they do not understand. You can check their understanding by asking them some questions about the information covered in the unit. Explain anything that students do not understand.

### Key words

- bell** – a hollow metallic device that is shaped somewhat like a cup and makes a ringing sound when struck
- brass instrument** – a musical instrument that produces sound by sympathetic vibration of air in a tubular resonator in sympathy with the vibration of the player's lips
- clarinet** – a musical instrument belonging to the group known as the woodwind instruments; it has a single-reed mouthpiece, a straight cylindrical tube with an almost cylindrical bore, and a flared bell
- drum** – a member of the percussion group of musical instruments
- echo** – a sound that is a copy of another sound and that is produced when sound waves bounce off a surface (such as a wall)

**flute** – a musical instrument in the woodwind group; an aerophone or reedless wind instrument that produces its sound from the flow of air across an opening

**fret** – one of a series of ridges fixed across the fingerboard of a stringed musical instrument (as a guitar)

**guitar** – a stringed musical instrument (see strings) usually played by strumming or plucking

**hearing aid** – small device that fits in or on the ear, worn by a partially deaf person to amplify sound

**percussion instrument** – a musical instrument that is sounded by being struck or scraped by a beater; struck, scraped or rubbed by hand; or struck against another similar instrument

**piano** – musical instrument having steel wire strings that sound when struck by felt-covered hammers operated from a keyboard

**reed** – a thin flexible piece of cane, plastic, or metal fastened to the mouthpiece of an instrument (as on a clarinet) or over an air opening in an instrument (as on an accordion) and made to vibrate by an air current

**reverberation** – in acoustics, the persistence of sound after a sound is produced

**saxophone** – a woodwind instrument, usually in the form of a curved metal tube with keys used to change pitch and a mouthpiece with a single reed

**sonar** – a system for the detection of objects under water and for measuring the water's depth by emitting sound pulses and detecting or measuring their return after being reflected

**sounding board** – a board or screen placed over or behind a pulpit or stage to reflect sound forward

**stringed instrument** – musical instruments that produce sound by vibrating strings

**submarine** – a vessel that can be submerged and navigated under water

**talking drum** – an hourglass-shaped drum from West Africa

**tone hole** – an opening in the body of a wind instrument which, when alternately closed and opened, changes the pitch of the sound produced

**trumpet** – a musical instrument with the highest register in the brass family

**wind instrument** – a family of musical instruments that contains some type of resonator (usually a tube), in which a column of air is set into vibration by the player blowing into (or over) a mouthpiece set at the end of the resonator

**woodwind instrument** – any one of the group of musical instruments that includes flutes, clarinets, oboes, bassoons, and saxophones

## Practice test: Answers

- 1.1 B                      1.6 A  
1.2 C                      1.7 D  
1.3 A                      1.8 C  
1.4 D                      1.9 C  
1.5 A                      1.10 B ( $2 \times 10 = 20$ )
2. Similarities: both are woodwind instruments; both have tone holes which be used to change the length of the pipes. (2)  
Differences: the clarinet is a pipe with one end closed, while the flute is a pipe with both ends opened; the fundamental frequency of the flute is larger than that of the clarinet. (2)
3. Similarities: both are pipes with one end opened and the other closed; both have bell ends; both are wind instruments. (2)  
Differences: the amplitude of the waves in a saxophone decrease as they move towards the bell end, while the trumpet's waves have constant amplitude; the saxophone has tone holes to change the length of the pipe, while the trumpet has pistons and valves to change the length of the pipe; the saxophone has a fundamental frequency while the trumpet does not. (2)
4. Similarities: both are string instruments; both have sound boards to amplify the sound. (2)  
Differences: the guitar has fewer strings than the piano; the guitar has frets to change the frequencies, while the piano has a damper to stop a note before the next note is played. (2)
5. a)  $f_1 = \frac{v}{2L} = \frac{340 \text{ m/s}}{2 \times 0.44 \text{ m}} = 386.4 \text{ Hz}$   
The first overtone is the second harmonic and is given by:  
 $f_2 = 2f_1 = 772.7 \text{ Hz}$  (3)
- b) The fundamental frequency for 44 cm will be larger than for 66 cm.  
The fundamental frequency for 66 cm is given by:  
 $f_1 = \frac{v}{2L} = \frac{340 \text{ m/s}}{2 \times 0.66 \text{ m}} = 257.6 \text{ Hz}$  (2)

- c) Fundamental frequency



First overtone



6. a) From  $f_1 = \frac{v}{2L}$ , we have:  
 $v = 2f_1L = 2 \times 329.6 \text{ Hz} \times 0.65 \text{ m}$   
 $= 428.5 \frac{\text{m}}{\text{s}}$  (3)

- b) (2)

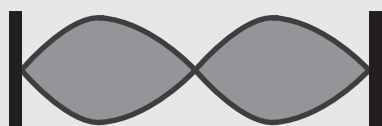

- c) We need to first determine the speed of the waves in the second string, by using the fundamental frequency of 329.6 Hz and length of 48.69 cm.

$$v' = 2f'_1L' = 2 \times 329.6 \text{ Hz} \times 0.4869 \text{ m} = 320.96 \text{ m/s}$$

Since this speed in the second string will remain constant, we can use it for the full length of 65 cm to determine the fundamental frequency.

$$f''_1 = \frac{v'}{2L''} = \frac{320.96 \text{ m/s}}{2 \times 0.65 \text{ m}} = 246.9 \text{ Hz} \quad (3)$$

7. a) To set the string into vibration. (1)

8. The audience in a concert hall hear sounds emanating directly from the performer and also the sounds reflected off the walls and roof of

the concert hall. The concert hall is designed such that all these sounds arrive at the same time to the listener. (2)

9. The diagram for the arrangement is as follows:

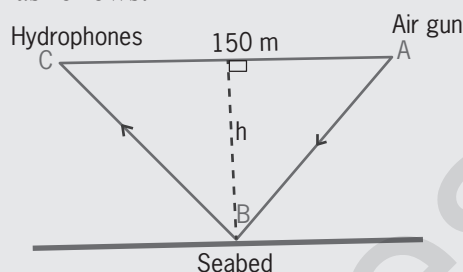

The time taken for the sonar wave to reach the hydrophones travelling through the air is:

$$t = \frac{s}{v} = \frac{150 \text{ m}}{330 \text{ m/s}} = 0.454 \text{ s}$$

The time taken for the sonar wave to reach the hydrophones travelling through the water is:

$$t = 0.454 \text{ s} + 2 \text{ s} = 2.454 \text{ s}$$

The distance travelled by the sonar wave in the water is:

$$s = vt = 1500 \text{ m/s} \times 2.454 \text{ s} = 3681.8 \text{ m, which is distance ABC in the above diagram.}$$

Therefore,  $AB = 1840.9 \text{ m}$

$$h^2 = (1840.9 \text{ m})^2 - (75 \text{ m})^2$$

$$h = 1842 \text{ m} \quad (6)$$

10. Microphone – converts sound waves into digital signals

Amplifier – strengthens the digital signals

Speaker – converts the digital signals into vibrations which then pass through the inner ear to the brain

Battery – powers the hearing aid

Microchip – helps to personalise the hearing aid to suit individual needs (5)

**Total mark: 63**

## TOPIC 1: Molecular theory of matter

### Performance objectives

- 1.1 state the fundamental assumptions of the molecular theory
- 1.2 use the molecular model to explain:
- **pressure** in a gas
  - **cohesion** and adhesion
  - **diffusion**

## Introduction

Some of the contents of this topic have already been discussed in Senior Secondary 1, and some of them earlier in this textbook. You should revise the previous concepts encountered and then extend and consolidate them into this topic.

### Activity 5.1: Investigate the effect of adhesive and cohesive forces on the meniscus of liquids

GROUPS (SB p. 227)

### Resources

Two beakers, two narrow glass tubes of equal diameter, water and mercury

### Guidelines

Assist and support students in this investigation.

### How are you doing? (SB p. 230)

Take this opportunity to ask students if there is anything that they do not understand. You can check their understanding by asking them some questions about the information covered in the unit. Explain anything that students do not understand.

### Key words

**adhesive forces** – the attractive forces between unlike molecules

**capillary action** – the movement of a liquid through or along the surface of another material in spite of other forces, such as gravity

**cohesive forces** – the intermolecular forces which cause a tendency in liquids to resist separation

**concentration** – concentrated mass or thing

**diffusion** – the movement of particles from a region of higher concentration to a region of lower concentration

## Practice test: Answers

- 1.1 C  
1.2 B  
1.3 D  
1.4 B  
1.5 A  $(5 \times 2 = 10)$
2. According to the molecular theory of matter, the gas molecules are in continuous random motion. This random motion results in the gas molecules making many collisions with the walls of the vessel containing them. The collisions lead to changes in momentum of the molecules. The rate of change in momentum arising from the collisions results in a force being exerted by the molecules on the walls of the container. The pressure exerted by the gas is then given by  $p = F/A$ , where  $A$  the area on which the force is exerted. (3)
3. When the volume of the gas is decreased at constant temperature, the same number of molecules having the same average kinetic energies as before now occupy the decreased volume. However, the molecules now move over shorter distances before they collide with the walls of the container because of the decreased space they now have. This increases the number of collisions per second which the molecules make with the walls of the container, and this results in an increase in the pressure of the gas. (3)
4. Water moving up a capillary tube, and the concave meniscus of water. (2)
5. The cohesive forces in mercury are stronger than the adhesive forces between the mercury molecules and the glass, hence there is no capillary action. (2)
6. a) The water molecules are in continuous random motion. This random motion makes them collide with the copper sulphate molecules and disperses them throughout the beaker of the water. The water then appears blue because of the presence of the copper sulphate molecules. (3)  
b) Diffusion (1)  
c) The colour change will occur in a shorter time. (1)

**Total mark: 25**

## TOPIC 1: Applications of lenses and plane mirrors

## Performance objectives

- 1.1 construct:
- a periscope
  - a box camera
  - a compound microscope
  - a telescope
  - a film projector
- 1.2 explain the optical principles involved in:
- the snapshot camera
  - the enlarging camera
  - the copying camera
- 1.3 set up a single-lens projector and use it to project a filmstrip on a screen
- 1.4 explain the formation of images by the camera and the projector by tracing rays of light through them
- 1.5 trace the paths of light rays through simple and compound microscopes and a telescope

## Introduction

Mirrors and lenses are an everyday part of our lives, and as such students are likely to take an active interest in the physics of reflection and refraction, and in the instruments – both ‘domestic’ and scientific – which depend on the properties of mirrors and lenses. You should attempt, therefore, to capitalise on the potential of this subject to ‘focus’ the attention of your students.

### Activity 6.1: Find the meaning of the word ‘periscope’

INDIVIDUAL (SB p. 233)

#### Guidelines

This is a dictionary exercise to find the meaning of ‘periscope’.

#### Answer

The word means ‘to see around’ – as in seeing around a corner, or over an obstruction.

### Activity 6.2: Make and use a pinhole camera

PAIRS OR SMALL GROUPS (SB p. 234)

#### Resources

A box about the size of a shoe box, and access to scissors (each group)

#### Guidelines

Students make a small round hole in one end of the box, and cut one side of the box so that it can be opened as a flap, allowing the back of the box to be seen. The end of the box with the pin hole is pointed at a brightly-lit subject, and the image is viewed through the flap on the side.

### Activity 6.3: Produce an image on a screen

SMALL GROUPS (SB p. 236)

#### Guidelines

It is unlikely that the school laboratory will have enough lenses to provide for all the groups for this and the next activity. Indeed it may not have any suitable lenses. You may be able to get convex lenses from an optician.

### Activity 6.4: Examine and experiment with a convex lens

INDIVIDUAL (SB p. 237)

#### Guidelines

Direct the students to Figure 6.8 which shows the basics of the experiment.

### Activity 6.5: Examine various optical instruments

INDIVIDUAL (SB p. 240)

#### Guidelines

The school may own a projector, and if it has a photographic club, it may have an enlarger. Individual students may be able to bring a pair of binoculars or a camera to school.

Tell students about care of lenses – not to touch the lens surface with fingers or any hard object; to clean the lens(es) when necessary with a soft, clean cloth or a soft brush.

### How are you doing?

(SB p. 241)

Take this opportunity to ask students if there is anything that they do not understand. You can check their understanding by asking them some questions about the information covered in the unit. Explain anything that students do not understand.

### Key words

**monocular** – modified refracting telescope used to magnify the images of distant objects by passing light through a series of lenses and sometimes prisms

**paraboloid** – surface having parabolic sections parallel to a single co-ordinate axis and elliptic sections perpendicular to that axis

## Practice test: Answers

- The Galilean telescope differs from an astronomical telescope in that the Galilean telescope shows an upright image, has a diverging (concave) rather than converging (convex) eyepiece lens, and the eyepiece of the Galilean telescope is placed just before the focal point of the objective lens. (6)
- The correct answer is a). (2)
- The correct answer is c). (2)
- A diverging lens produces a 'virtual' image, which is on the same side of the lens as the object. A convex lens produces a 'real' image on the opposite side of the lens from the object. For these reasons the focal length of a diverging (concave) lens is given as a negative value. (2)
- If the object is closer to the lens than the focal length of the lens a real image will not be formed by the lens. (2)
- Magnification  $(m) = \frac{F(\text{objective})}{F(\text{eyepiece})}$ , thus if  $m = 200$  times,  $F(\text{eyepiece}) = \frac{300}{200} = 1.5 \text{ cm}$ . (4)

**Total mark: 18**

## TOPIC 2: Musical instruments

### Performance objectives

2.1 construct various musical instruments

### Introduction

As you will realise, this topic is not like the other topics that have explanatory teaching text, numerous activities and summary/practice tests. The topic is more akin to a project for the students. No textbook can outline every musical instrument used in Nigeria and give details on how to construct them.

### Activity 6.6: Identify, classify and construct a local musical instrument

INDIVIDUAL (SB p. 242)

#### Guidelines

Try to show your students musical instruments used in the locality. You could invite an expert to give a talk on the contribution of local musical instruments to the entertainment industry.

Advise students to consult the website [www.pinterest.com](http://www.pinterest.com) for Music DIY to help them to construct their own musical instruments. There are also numerous videos on YouTube that can show them how to make the musical instrument of their choice.

For Ebook Uses

For Ebook Uses